



# IDTA 02026-1-0

## Provision of 3D Models

June 2024

**SPECIFICATION**

Submodel Template of the  
Asset Administration Shell



Submodel Template

**IDTA** approved

- 100% AAS compliant
- Consistent & interoperable
- Released by the AAS experts

# Imprint

## **Publisher**

Industrial Digital Twin Association  
Lyoner Straße 18  
60528 Frankfurt am Main  
Germany  
<https://www.industrialdigitaltwin.org/>

## Version history

<b>Date</b>	<b>Version</b>	<b>Comments</b>
2024-06-14	1.0	Release of the official Submodel template published by IDTA.

# Contents

1	General .....	12
1.1	About this document .....	12
1.2	Scope of the Submodel .....	12
1.3	Relevant standards for the Submodel template .....	12
1.4	Use cases, requirements and design decisions .....	13
1.4.1	Use Cases .....	13
1.4.2	Requirements.....	14
1.4.3	Design decisions.....	14
2	SMT IDTA 02026 – Provision of 3D Models.....	15
2.1	Approach.....	15
2.2	Data Model – Provision Of 3D Models .....	17
2.2.1	[SM] Models3D .....	17
2.2.2	[SMC] File .....	19
2.2.3	[SMC] Capability .....	66
2.2.4	[SMC] Geometry .....	76
2.3	Predefined ValueLists.....	101
2.4	Common SubmodelElements [SME] within SMT Provision of 3D Models .....	110
Annex A.	Explanations on used table formats .....	124
1.	General .....	124
2.	Tables on Submodels and SubmodelElements.....	124
Annex B.	Application guidelines and scenarios .....	125
1.	Guidelines .....	125
1.1.	Avoid providing more 3D model files than necessary .....	125
1.2.	Avoid redefining geometric information .....	125
Annex C.	Backlog .....	127
Annex D.	Diagrams.....	129
	Bibliography .....	130

# Figures

Figure 1:	Main Use Case – Overview .....	13
Figure 2:	UML   SMT IDTA 02026-1-0 Provision of 3D Models.....	16
Figure 3:	[SM] IDTA 02026-1-0 – Structure overview – SMC.....	16
Figure 4:	[SM] IDTA 02026-1-0 – Structure overview value lists and common SME .....	17
Figure 5:	[SM] Model3D – Overview .....	17
Figure 6:	[SM] Models3D .....	18
Figure 7:	[SM] Models3D .....	18
Figure 8:	[SML][SMC] Model3D .....	19
Figure 9:	[SMC] File .....	20
Figure 10:	[SMC] File .....	21
Figure 11:	[SML][SMC] FileId.....	22
Figure 12:	[Prop] FileDomainId .....	23
Figure 13:	[Prop] ValueId .....	23
Figure 14:	[Prop] IsPrimary .....	24
Figure 15:	[SML][SMC] FileVersion .....	25
Figure 16:	[MLP] Title.....	27
Figure 17:	[Prop] FileName .....	28
Figure 18:	[Prop] FileVersionId .....	28
Figure 19:	[Prop] StatusValue .....	29
Figure 20:	[Prop] SetDate .....	29
Figure 21:	[SML][Ref] BasedOn.....	30
Figure 22:	[SML][Ref] RefersTo .....	31
Figure 23:	[File] PreviewFile .....	32
Figure 24:	[File] DigitalFile .....	33
Figure 25:	[SML][SMC] ExternalFile .....	34
Figure 26:	[Prop] ExternalUrl .....	35
Figure 27:	[Prop] FileIdentifier.....	35
Figure 28:	[SMC] HostOrganization .....	36
Figure 29:	[Prop] OrganizationName .....	37
Figure 30:	[Prop] OrganizationOfficialName .....	37
Figure 31:	[SML][SMC] Api .....	38
Figure 32:	[Prop] ApiVersion .....	39
Figure 33:	[Prop] ApiDocumentationUrl .....	39
Figure 34:	[Prop] ApiSpecificationUrl .....	40
Figure 35:	[SMC] FileFormat.....	41

Figure 36:	[Prop] FormatName .....	42
Figure 37:	[Prop] FormatVersion.....	42
Figure 38:	[Prop] FormatQualifier .....	43
Figure 39:	[SMC] SourceApplication.....	44
Figure 40:	[Prop] ApplicationName .....	45
Figure 41:	[Prop] ApplicationVersion .....	45
Figure 42:	[Prop] ApplicationQualifier .....	46
Figure 43:	[SML][SMC] Api .....	47
Figure 44:	[Prop] ApiVersion .....	48
Figure 45:	[Prop] ApiDocumentationUrl .....	48
Figure 46:	[Prop] ApiSpecificationUrl .....	49
Figure 47:	[SMC] VendorOrganization.....	50
Figure 48:	[Prop] OrganizationName .....	51
Figure 49:	[Prop] OrganizationOfficialName .....	52
Figure 50:	[SMC] ProvidingOrganization .....	53
Figure 51:	[Prop] OrganizationName .....	54
Figure 52:	[Prop] OrganizationOfficialName .....	54
Figure 53:	[SML][SMC] ConsumingApplication .....	55
Figure 54:	[Prop] ApplicationName .....	56
Figure 55:	[Prop] ApplicationVersion .....	56
Figure 56:	[Prop] ApplicationQualifier .....	57
Figure 57:	[SML][SMC] Api .....	58
Figure 58:	[Prop] ApiVersion .....	59
Figure 59:	[Prop] ApiDocumentation.....	59
Figure 60:	[Prop] ApiSpecificationUrl .....	60
Figure 61:	[SMC] VendorOrganization.....	61
Figure 62:	[Prop] OrganizationName .....	62
Figure 63:	[Prop] OrganizationOfficialName .....	63
Figure 64:	[SML][SMC] FileClassification .....	64
Figure 65:	[Prop] ClassId .....	65
Figure 66:	[MLP] ClassName .....	65
Figure 67:	[Prop] ClassificationSystem.....	66
Figure 68:	[SMC] Capability .....	66
Figure 69:	[SMC] Capability .....	67
Figure 70:	[SML][Prop] PosModelPurpose .....	68
Figure 71:	[SML][Prop] NegModelPurpose.....	69
Figure 72:	[Prop] EmbeddedInfo.....	70
Figure 73:	[SML][Prop] State .....	71

Figure 74:	[Prop] ObjectType .....	72
Figure 75:	[Prop] Origin .....	73
Figure 76:	[SMC] Simplification .....	74
Figure 77:	[Prop] Description .....	75
Figure 78:	[SML][Prop] ReducedElements .....	75
Figure 79:	[Ref] DerivedFrom .....	76
Figure 80:	[SMC] Geometry .....	76
Figure 81:	[SMC] Geometry .....	77
Figure 82:	[Prop] Representation .....	78
Figure 83:	[Prop] LengthUnit .....	78
Figure 84:	[SML][SMC] CartBoundingBox .....	79
Figure 85:	[Prop] BoundingBoxKind .....	80
Figure 86:	[SMC] CartRefSystem .....	81
Figure 87:	[SMC] CartOffsetVector .....	82
Figure 88:	[Prop] X .....	83
Figure 89:	[Prop] Y .....	84
Figure 90:	[Prop] Z .....	85
Figure 91:	[SML][SMC] NormOrientationVector .....	86
Figure 92:	[Prop] X .....	87
Figure 93:	[Prop] Y .....	88
Figure 94:	[Prop] Z .....	89
Figure 95:	[SMC] CartBoundingVector .....	90
Figure 96:	[Prop] X .....	91
Figure 97:	[Prop] Y .....	92
Figure 98:	[Prop] Z .....	93
Figure 99:	[SML][SMC] CartRefSystem .....	94
Figure 100:	[SMC] CartOffsetVector .....	95
Figure 101:	[Prop] X .....	96
Figure 102:	[Prop] Y .....	96
Figure 103:	[Prop] Z .....	97
Figure 104:	[SML][SMC] NormOrientationVector .....	98
Figure 105:	[Prop] X .....	99
Figure 106:	[Prop] Y .....	100
Figure 107:	[Prop] Z .....	101
Figure 108:	Predefined ValueLists – Overview .....	101
Figure 109:	ValueList – ObjectType .....	102
Figure 110:	ValueList – Origin .....	103
Figure 111:	ValueList – EmbeddedInfo .....	104

Figure 112:	ValueList – State .....	105
Figure 113:	ValueList – ModelPurpose .....	106
Figure 114:	ValueList – ReducedElements .....	107
Figure 115:	ValueList – StatusValue .....	108
Figure 116:	ValueList – Representation .....	109
Figure 117:	ValueList – BoundingBoxKind .....	110
Figure 118:	Common SubmodelElements [SME] within [SMT] Provision of 3D Models – Overview .....	110
Figure 119:	CommonSubmodelElement [SMC] Application .....	111
Figure 120:	CommonSubmodelElement [Prop] ApplicationName .....	112
Figure 121:	CommonSubmodelElement [Prop] ApplicationVersion .....	112
Figure 122:	CommonSubmodelElement [Prop] ApplicationQualifier .....	113
Figure 123:	CommonSubmodelElement [SMC] Api .....	114
Figure 124:	CommonSubmodelElement [Prop] ApiVersion .....	115
Figure 125:	CommonSubmodelElement [Prop] ApiDocumentationUrl .....	115
Figure 126:	CommonSubmodelElement [Prop] ApiSpecificationUrl .....	116
Figure 127:	CommonSubmodelElement [SMC] Organization .....	117
Figure 128:	CommonSubmodelElement [Prop] OrganizationName .....	118
Figure 129:	CommonSubmodelElement [Prop] OrganizationOfficialName .....	118
Figure 130:	CommonSubmodelElement [Prop] ModelPurpose .....	119
Figure 131:	CommonSubmodelElement [SMC] CartRefSystem .....	120
Figure 132:	CommonSubmodelElement [SMC] CartVector .....	121
Figure 133:	CommonSubmodelElement [Prop] X .....	122
Figure 134:	CommonSubmodelElement [Prop] Y .....	122
Figure 135:	CommonSubmodelElement [Prop] Z .....	123
Figure 136:	UML   SMT IDTA 02026-1-0 Provision of 3D Models – enlarged .....	129

# Tables

Table 1:	Package Overview .....	15
Table 2:	[SM] Models3D .....	18
Table 3:	[SML][SMC] Model3D .....	19
Table 4:	[SMC] File .....	21
Table 5:	[SML][SMC] FileId .....	22
Table 6:	[Prop] FileDomainId .....	23
Table 7:	[Prop] ValueId .....	23
Table 8:	[Prop] IsPrimary .....	24
Table 9:	[SML][SMC] FileVersion .....	25
Table 10:	[MLP] Title .....	27
Table 11:	[Prop] FileName .....	28
Table 12:	[Prop] FileVersionId .....	28
Table 13:	[Prop] StatusValue .....	29
Table 14:	[Prop] SetDate .....	29
Table 15:	[SML][Ref] BasedOn .....	30
Table 16:	[SML][Ref] RefersTo .....	31
Table 17:	[File] PreviewFile .....	32
Table 18:	[File] DigitalFile .....	33
Table 19:	[SML][SMC] ExternalFile .....	34
Table 20:	[Prop] ExternalUrl .....	35
Table 21:	[Prop] FileIdentifier .....	35
Table 22:	[SMC] HostOrganization .....	36
Table 23:	[Prop] OrganizationName .....	37
Table 24:	[Prop] OrganizationOfficialName .....	37
Table 25:	[SML][SMC] Api .....	38
Table 26:	[Prop] ApiVersion .....	39
Table 27:	[Prop] ApiDocumentationUrl .....	39
Table 28:	[Prop] ApiSpecificationUrl .....	40
Table 29:	[SMC] FileFormat .....	41
Table 30:	[Prop] FormatName .....	42
Table 31:	[Prop] FormatVersion .....	42
Table 32:	[Prop] FormatQualifier .....	43
Table 33:	[SMC] SourceApplication .....	44
Table 34:	[Prop] ApplicationName .....	45
Table 35:	[Prop] ApplicationVersion .....	45

Table 36:	[Prop] ApplicationQualifier .....	46
Table 37:	[SML][SMC] Api .....	47
Table 38:	[Prop] ApiVersion .....	48
Table 39:	[Prop] ApiDocumentationUrl .....	48
Table 40:	[Prop] ApiSpecificationUrl .....	49
Table 41:	[SMC] VendorOrganization .....	50
Table 42:	[Prop] OrganizationName .....	51
Table 43:	[Prop] OrganizationOfficialName .....	52
Table 44:	[SMC] ProvidingOrganization .....	53
Table 45:	[Prop] OrganizationName .....	54
Table 46:	[Prop] OrganizationOfficialName .....	54
Table 47:	[SML][SMC] ConsumingApplication .....	55
Table 48:	[Prop] ApplicationName .....	56
Table 49:	[Prop] ApplicationVersion .....	56
Table 50:	[Prop] ApplicationQualifier .....	57
Table 51:	[SML][SMC] Api .....	58
Table 52:	[Prop] ApiVersion .....	59
Table 53:	[Prop] ApiDocumentation .....	59
Table 54:	[Prop] ApiSpecificationUrl .....	60
Table 55:	[SMC] VendorOrganization .....	61
Table 56:	[Prop] OrganizationName .....	62
Table 57:	[Prop] OrganizationOfficialName .....	63
Table 58:	[SML][SMC] FileClassification .....	64
Table 59:	[Prop] ClassId .....	65
Table 60:	[MLP] ClassName .....	65
Table 61:	[Prop] ClassificationSystem .....	66
Table 62:	[SMC] Capability .....	67
Table 63:	[SML][Prop] PosModelPurpose .....	68
Table 64:	[SML][Prop] NegModelPurpose .....	69
Table 65:	[SML][Prop] EmbeddedInfo .....	70
Table 66:	[SML][Prop] State .....	71
Table 67:	[Prop] ObjectType .....	72
Table 68:	[Prop] Origin .....	73
Table 69:	[SMC] Simplification .....	74
Table 70:	[Prop] Description .....	75
Table 71:	[SML][Prop] ReducedElements .....	75
Table 72:	[Ref] DerivedFrom .....	76
Table 73:	[SMC] Geometry .....	77

Table 74:	[Prop] Representation.....	78
Table 75:	[Prop] LengthUnit.....	78
Table 76:	[SML][SMC] CartBoundingBox.....	79
Table 77:	[Prop] BoundingBoxKind.....	80
Table 78:	[SMC] CartRefSystem.....	81
Table 79:	[SMC] CartOffsetVector.....	82
Table 80:	[Prop] X.....	83
Table 81:	[Prop] Y.....	84
Table 82:	[Prop] Z.....	85
Table 83:	[SML][SMC] NormOrientationVector.....	86
Table 84:	[Prop] X.....	87
Table 85:	[Prop] Y.....	88
Table 86:	[Prop] Z.....	89
Table 87:	[SMC] CartBoundingBoxVector.....	90
Table 88:	[Prop] X.....	91
Table 89:	[Prop] Y.....	92
Table 90:	[Prop] Z.....	93
Table 91:	[SML][SMC] CartRefSystem.....	94
Table 92:	[SMC] CartOffsetVector.....	95
Table 93:	[Prop] X.....	96
Table 94:	[Prop] Y.....	96
Table 95:	[Prop] Z.....	97
Table 96:	[SML][SMC] NormOrientationVector.....	98
Table 97:	[Prop] X.....	99
Table 98:	[Prop] Y.....	100
Table 99:	[Prop] Z.....	101
Table 100:	ValueList – ObjectType.....	102
Table 101:	ValueList – Origin.....	103
Table 102:	ValueList – EmbeddedInfo.....	104
Table 103:	ValueList – State.....	105
Table 104:	ValueList – ModelPurpose.....	106
Table 105:	ValueList – ReducedElements.....	107
Table 106:	ValueList – StatusValue.....	108
Table 107:	ValueList – Representation.....	109
Table 108:	ValueList – BoundingBoxKind.....	110
Table 109:	CommonSubmodelElement [SMC] Application.....	111
Table 110:	CommonSubmodelElement [Prop] ApplicationName.....	112
Table 111:	CommonSubmodelElement [Prop] ApplicationVersion.....	112

Table 112:	CommonSubmodelElement [Prop] ApplicationQualifier .....	113
Table 113:	CommonSubmodelElement [SMC] Api .....	114
Table 114:	CommonSubmodelElement [Prop] ApiVersion.....	115
Table 115:	CommonSubmodelElement [Prop] ApiDocumentationUrl.....	115
Table 116:	CommonSubmodelElement [Prop] ApiSpecificationUrl.....	116
Table 117:	CommonSubmodelElement [SMC] Organization .....	117
Table 118:	CommonSubmodelElement [Prop] OrganizationOfficialName .....	118
Table 119:	CommonSubmodelElement [Prop] OrganizationOfficialName .....	118
Table 120:	CommonSubmodelElement [Prop] ModelPurpose .....	119
Table 121:	CommonSubmodelElement [SMC] CartRefSystem .....	120
Table 122:	CommonSubmodelElement [SMC] CartVector .....	121
Table 123:	CommonSubmodelElement [Prop] X.....	122
Table 124:	CommonSubmodelElement [Prop] Y.....	122
Table 125:	CommonSubmodelElement [Prop] Z.....	123
Table 126:	Backlog .....	127

# 1 General

## 1.1 About this document

This document is a part of a specification series. Each part specifies the contents of a Submodel template for the Asset Administration Shell (AAS). The AAS is described in [1], [2], [3] and [6]. First exemplary Submodel contents were described in [4], while the actual format of this document was derived by the "Administration Shell in Practice" [5]. The format aims to be very concise, giving only minimal necessary information for applying a Submodel template, while leaving deeper descriptions and specification of concepts, structures and mapping to the respective documents [1] to [6].

The target group of the specification are developers and editors of technical documentation and manufacturer information, which are describing assets in smart manufacturing by means of the Asset Administration Shell (AAS) and therefore need to create a Submodel instance with a hierarchy of SubmodelElements. This document especially details on the question, which SubmodelElements with which semantic identification shall be used for this purpose.

## 1.2 Scope of the Submodel

The general Scope of the specification IDTA SMT 020026 "Provision of 3D Models" with the Submodel "Models3D" aims to provide enough meta data to find the right file, to integrate the file in the right way and to do plausibility checks. The file can be either provided within the Submodel itself or, as recommended, with a link to an online file source. This Submodel should complement the existing 3D model file formats and is not meant to replace or redefine them. Nevertheless, meta data that is seen as relevant during the exchange (provision, search, integration) of 3D models but is not harmonized across the various 3D formats will be in the scope of this Submodel. Based on the experience of different stakeholders of the working group "Provision of 3D Models", for various reasons, there is still the demand for different 3D file formats, be it based on standards like ISO 10303 or proprietary software formats. The scope is based on the implemented use cases and might be extended in future versions of the AAS Submodel Template "Provision of 3D Models". The [SM] "Models 3D" is suitable for Asset Administration Shells (AAS) of the kind type and instance.

In short: the scope of the SubmodelTemplate IDTA 020026 "Provision of 3D Models" with the Submodel "Models3D" is the provision of 3D Models by complementing and not redefining the existing 3D Model formats themselves.

## 1.3 Relevant standards for the Submodel template

IDTA SubmodelTemplates:

- SMT IDTA 02004-1-2 "Handover Documentation" with [SM] "HandoverDocumentation"
  - basis for [SMC] "File" to provide and classify the 3D model file
- SMT IDTA 02005-1-0 "Provision of Simulation Models" with [SM] "SimulationModels"
  - general structure in first layers: [SM] "XModels" contains many [SMC] "XModel"
  - naming convention of SMT for further generic purposes "Provision of X Models", with "X" as a generic model type
  - concept of [SMC] "SimPurpose" as generic SME "PosModelPurpose" and "NegModelPurpose" respectively
  - concept of "value lists"

## 1.4 Use cases, requirements and design decisions

The SubmodelTemplate IDTA 02026 “Provision of 3D Models” with the [SM] “Models3D” is developed by the working group consisting of different stakeholders, such as machine builder, component supplier, CAD tool vendors, e-catalog and configurator vendors, as well as researchers.

### 1.4.1 Use Cases

The main aim of the SMT IDTA 02026 “Provision of 3D Models” is to enable customers to integrate the right 3D Model file – of the Asset of interest – that is suitable for their specific tool landscape. Figure 1 shows the overview of the main Use Cases. To do so, a supplier needs to provide the model file and meta data either directly to a customer or via a third party (catalogues, libraries, marketplaces) – further described in Use Case 1. A customer needs to search for the right model and integrate it with other [SM] for the corresponding Asset – further described in Use Case 2.

An overview of the issues elaborated from the use case discussions developed by the working group of the SMT IDTA 02026 “Provision of 3D Models” are stated in the backlog in Annex C.

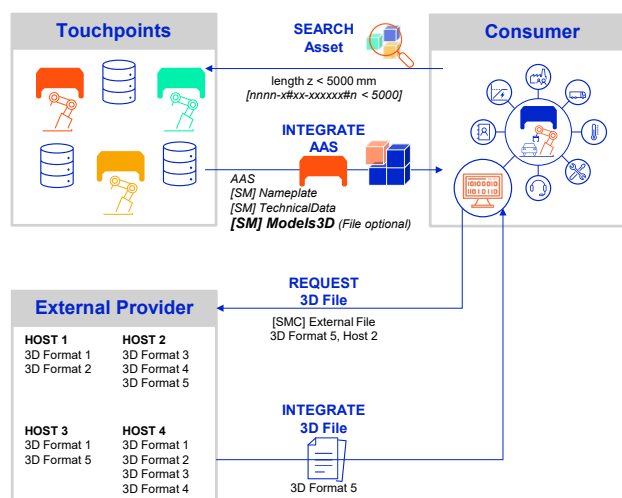

Figure 1: Main Use Case – Overview

#### Use Case 1: Search the right Asset

A customer shall be enabled to search the right Asset based on meta data specified in the [SM] Models3D. This could be e.g., some geometric information or some specific capability the 3D file needs to have.

#### Use Case 2: Integrate the AAS

The meta data needs to be integrated into the right places of the customers system landscape. Target systems are 3D model related systems (CAD, PLM, PDM, Simulation). The provision of a 3D model file here is optional (see use case 3: request 3D File).

#### Use Case 3: Request 3D model file

The meta data shall describe how to retrieve a specific file format from different external providers. This should also address the topic that not every available 3D model file format should be put inside the AASX package.

#### Use Case 4: Integrate 3D model file

The meta data shall support the integration of the 3D model file into the system landscape.

## 1.4.2 Requirements

### Geometry

The scope of this [SM] is not to redefine 3D file formats but to complement them to support the provision, search, and integration of the file, regardless of the file format itself. Only a very basic set of geometric information will be given to provide information about bounding boxes without opening the file itself.

### Reusability

One major approach is to model the structure of [SMC] as generic as possible to increase the degree of reusability within the Submodel itself, but also with the goal to be reused in other Submodels or at least to reuse modeling approaches and therefore reduce the adaption and integration effort of the SMT. The uniqueness is then given by the Semantic ID of each SME. To make it easier to follow this concept, two additional packages inside the UML diagram were introduced: "SME | Common" for common and reusable SME modeling approaches as well as "ValueLists | ValueLists" for values that should be used for some properties with a defined semantic. It is important to note, that this use of "ValueLists | ValueLists" and the "SME | Common" are not covered by the meta model of the Asset Administration Shell and therefore not a technical part of the implementation. Packages are also no part of the meta model of the Asset Administration Shell and used in the UML class diagrams to show a conceptual distinction between the main [SMC] and to support the reusability of concepts for further Submodel developments.

### Type AAS and Instance AAS

The asset represented by the AAS is of kind "type" or "instance".

## 1.4.3 Design decisions

### Bill of materials (BOM)

The [SM] "Models3D" does not rely on the SMT IDTA 02011 "Hierarchical Structures enabling Bills of Material" with the [SM] "HierarchicalStructures", or similar. The scope of the [SM] "Models3D" is to provide 3D model files of every kind (e.g., part or assembly) and a basic set of geometric information, but not enough to define the interfaces between the different kinds as this will remain within the 3D model files itself. Therefore, a direct reference to the [SM] "HierarchicalStructures" is not implemented.

### Geometry

Since the geometry should remain in general in the 3D model file itself, a basic description of bounding boxes and the possibility to add reference vectors as part of the [SM] "Models3D" is seen as a benefit especially in terms of plausibility checks. To keep it simple it is based on cartesian coordinates only.

### File provision

Concepts of the SMT IDTA 02004-1-2 "Handover Documentation" with the [SM] "HandoverDocumentation", as well as SMT IDTA 02005-1-0 "Provision of Simulation Models" with [SM] "SimulationModels" are suitable for the provision of 3D Models as well. Therefore, based on the first levels structure of [SM] "SimulationModels", a major part of the [SM] "HandoverDocumentation" is reused and adapted for the provision of the 3D model file or an external link to 3D model files.

## 2 SMT IDTA 02026 – Provision of 3D Models

### 2.1 Approach

Starting from the prioritized use case list, three main Submodel Element Collections [SMC] related to a 3D model were defined, that are in general independent of each other: File, Capability, Geometry. These three [SMC] were then developed further, all under the consideration of existing Submodels. Furthermore, the Submodel Element Collections [SMC] File and [SMC] Capability together with the [SM] Model3D and [SMC] Models3D are grouped to the package “SME | ProvisionOfModels” as the structure might be applied in future [SM] developments to the provision of other models.

As mentioned in 1.4.2 Requirements, the packages “ValueLists | ValueLists” and “SME | Common” are introduced to support the reusability of concepts and values. Important to note that these elements are not part of the technical implementation. Elements of and relations to the package “ValueLists | ValueLists” are shown in green color and elements of and relations to the package “SME | Common” are shown in turquoise color. Elements and relations of both packages mentioned before are shown – besides the regular [SME] – at the beginning of each main [SMC] chapter. Table 1 gives an overview of the packages.

**Table 1: Package Overview**

Package Name	Description@en	Chapter	Part of SM	Color
SME   ProvisionOfModels	Contains the [SM] Models3D as well as the [SMC] “File” and “Capability” with the general purpose to provide a model and support provision, search, and integration of it.	2.2.1 2.2.2 2.2.3	yes	Blue #0026CC
SME   Geometry	Contains the [SMC] “Geometry” with basic set of geometric cartesian vectors and further properties to describe bounding boxes and reference points.	2.2.4	yes	Blue #0026CC
SME   Common	Contains SMEs that are reused – on a conceptual level, not on a modeling level – within the [SM] “Models3D”.	2.4	no	Grey #D1D1D1
ValueLists   ValueLists	Contains lists with predefined values that should be used for the respective properties. These value lists are not part of the model. Orientation on IDTA 02005-1-0 Provision of Simulation Models chapter 2.19 Predefined values for properties.	2.3	no	Green #00F1AB

Figure 2 shows the complete UML diagram of the SMT IDTA “02026-1-0 Provision of 3D Models” including the [SM] “Model3D”, showing the grouping into packages, as well as the [SME] and connections of the packages “ValueLists | ValueLists” and “SME | Common”. Annex D shows the diagram in a larger scale. Parts of the diagram are used at the beginning of each main [SMC] chapter as well as in every [SME] table.

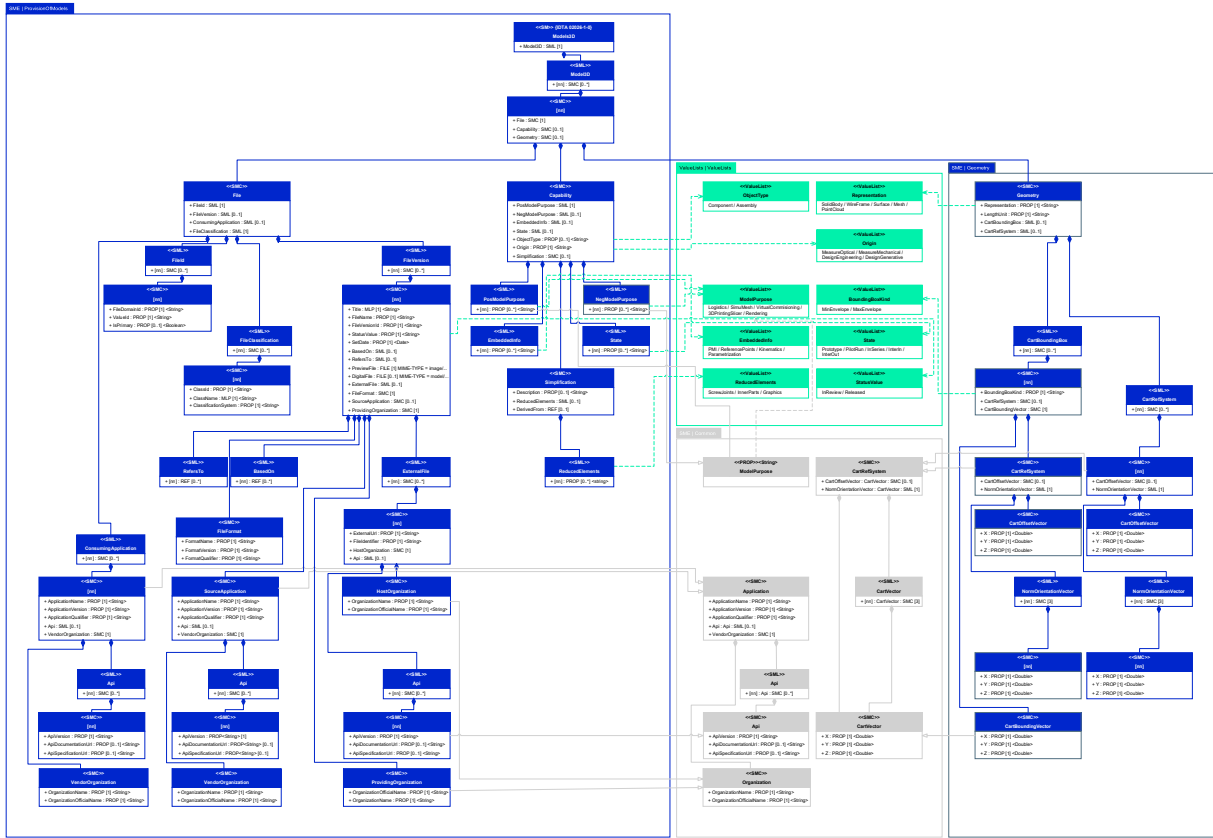

Figure 2: UML | SMT IDTA 02026-1-0 Provision of 3D Models

Figure 3 and Figure 4 show the structure overview of the [SM] “Models3D”, the value lists, as well as the common SMEs. Parts of the diagrams are used in every SME table to indicate the location of the SMEs.

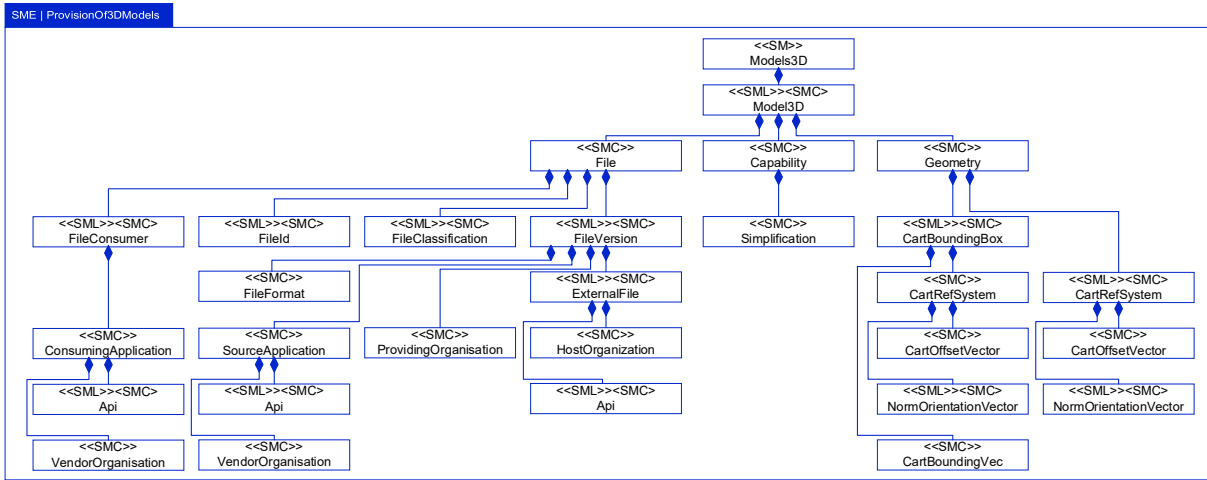

Figure 3: [SM] IDTA 02026-1-0 – Structure overview – SMC

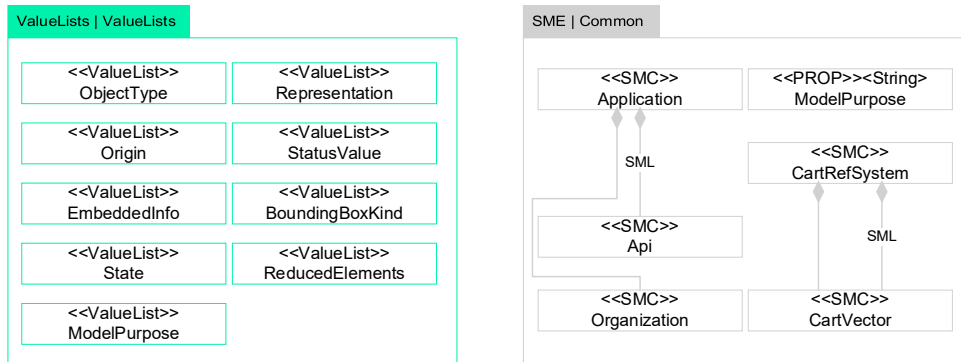

Figure 4: [SM] IDTA 02026-1-0 – Structure overview value lists and common SME

## 2.2 Data Model – Provision Of 3D Models

This chapter 2.2 contains the detailed description of the data model for the SMT IDTA “02026-1-0 Provision of 3D Models” including the [SM] “Model3D” as it is realized as an AAS SM. This chapter is divided into five subchapters:

- 2.2.1 – [SM] Models3D
- 2.2.2 – [SMC] File
- 2.2.3 – [SMC] Capability
- 2.2.4 – [SMC] Geometry

Predefined values for some of the properties are found in chapter 2.3.

Figure 5 shows the overview of the [SM] “Model3D”.

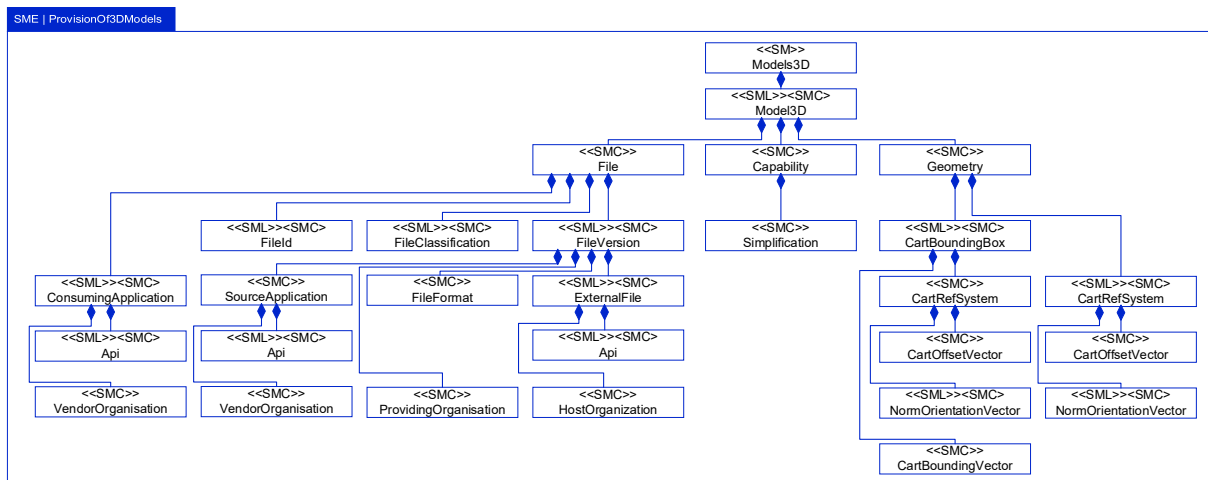

Figure 5: [SM] Model3D – Overview

### 2.2.1 [SM] Models3D

Figure 6 shows an overview of the first levels of the [SM] Models3D. In the chapters that follow the three Submodel Element Collections [SMC] File, [SMC] Capability and [SMC] Geometry are described in detail.

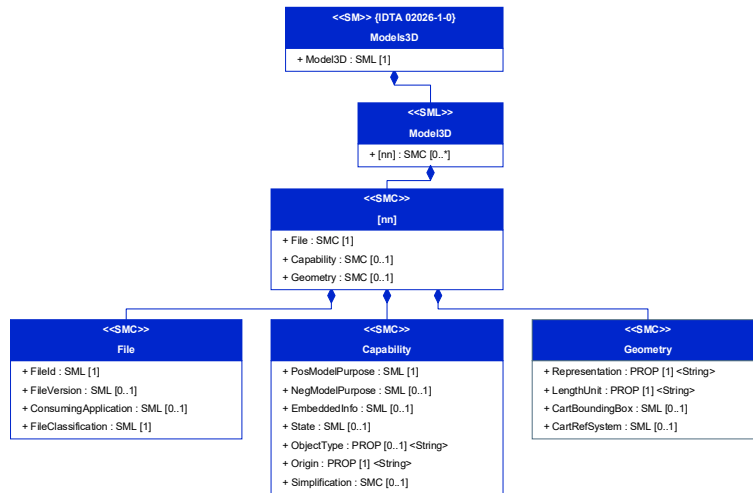

Figure 6: [SM] Models3D

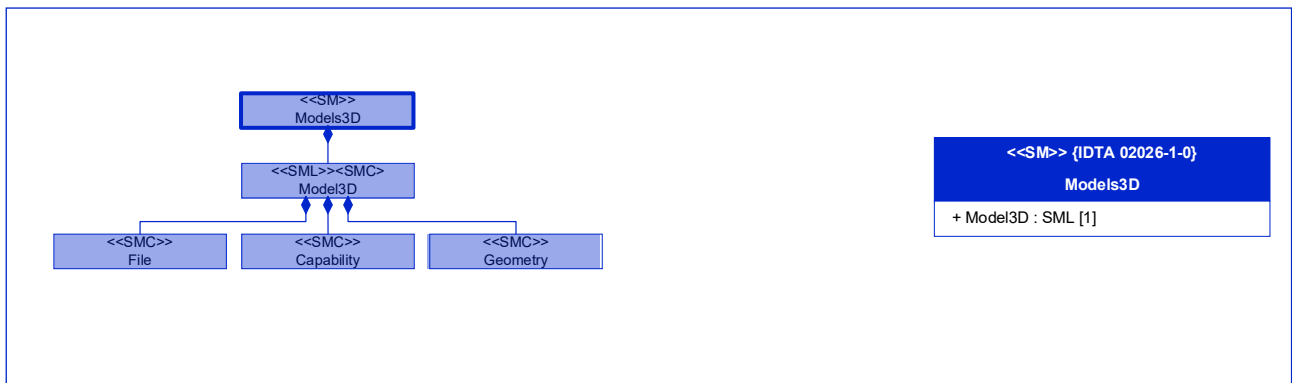

Figure 7: [SM] Models3D

Table 2: [SM] Models3D

<b>idShort:</b>	Models3D		
<b>Class:</b>	Submodel [SM]		
<b>semanticId:</b>	[IRI] <a href="https://admin-shell.io/idta/Models3D/1/0">https://admin-shell.io/idta/Models3D/1/0</a>		
<b>Parent:</b>	Asset Administration Shell, to which the 3D Models shall be associated to.		
<b>Explanation:</b>	This Submodel provides one or more 3D model files or a link to the model files, as well as meta information about them. Aim is to support the search, the integration and the usage of 3D models.		
<b>[SME type]</b>	<b>semanticId = [idType]value</b>	<b>[valueType]</b>	<b>card.</b>
<b>idShort</b>	<b>Description@en</b>	<b>example</b>	
[SML][SMC] Model3D	[IRI] <a href="https://admin-shell.io/idta/Models3D/Model3D/1/0">https://admin-shell.io/idta/Models3D/Model3D/1/0</a> List that contains Model3D entities.	[n/a]	1

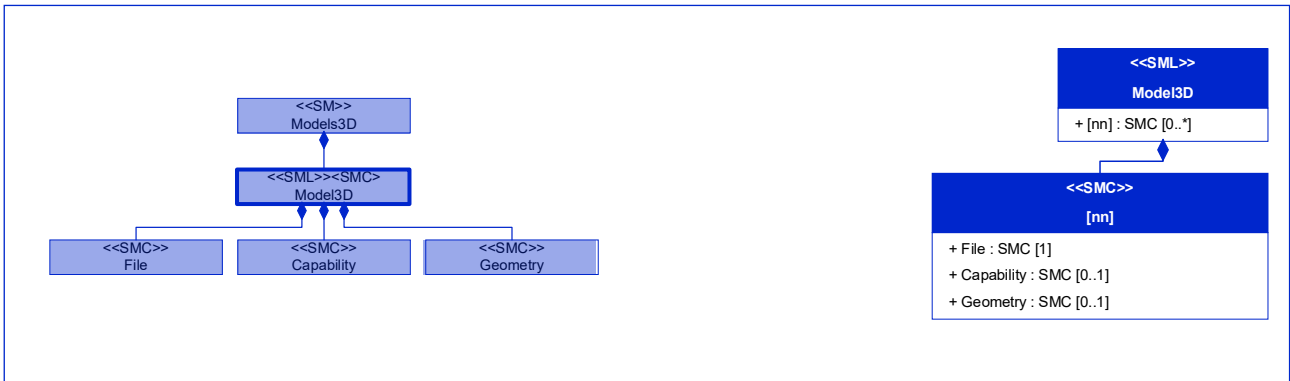

Figure 8: [SML][SMC] Model3D

Table 3: [SML][SMC] Model3D

<b>idShort:</b>	Model3D		
<b>Class:</b>	SubmodelElementList [SML] that contains SubmodelElementCollections [SMC]		
<b>semanticId:</b>	[IRI] <a href="https://admin-shell.io/idta/Models3D/Model3D/1/0">https://admin-shell.io/idta/Models3D/Model3D/1/0</a>		
<b>Parent:</b>	[IRI] <a href="https://admin-shell.io/idta/Models3D/1/0">https://admin-shell.io/idta/Models3D/1/0</a> Models3D		
<b>Explanation:</b>	List that contains Model3D entities.		
<b>[SME type]</b>	<b>semanticId = [idType]value</b>	<b>[valueType]</b>	<b>card.</b>
<b>idShort</b>	<b>Description@en</b>	<b>example</b>	
[SMC] File	[IRI] <a href="https://admin-shell.io/idta/Models3D/Model3D/File/1/0">https://admin-shell.io/idta/Models3D/Model3D/File/1/0</a> Information about the model file entity. Contains the 3D model file, or external link to it.	[n/a]	1
[SMC] Capability	[IRI] <a href="https://admin-shell.io/idta/Models3D/Model3D/Capability/1/0">https://admin-shell.io/idta/Models3D/Model3D/Capability/1/0</a> Information about the model capability.	[n/a]	0..1
[SMC] Geometry	[IRI] <a href="https://admin-shell.io/idta/Models3D/Model3D/Geometry/1/0">https://admin-shell.io/idta/Models3D/Model3D/Geometry/1/0</a> Basic geometric information of the model.	[n/a]	0..1

### 2.2.2 [SMC] File

The [SMC] File adapts the basic structure and SMEs of the SMT “IDTA 02004-1-2 Handover Documentation”. “IDTA 02004-1-2” is extended by SMEs that describe the source application as well as possible consuming applications of the file. Besides describing SMEs, the [SMC] FileVersion contains the 3D model file itself, as well as a preview picture. Figure 9 shows the [SMC] File as well as the conceptual connection to the [ValueLists] and [CommonSME].

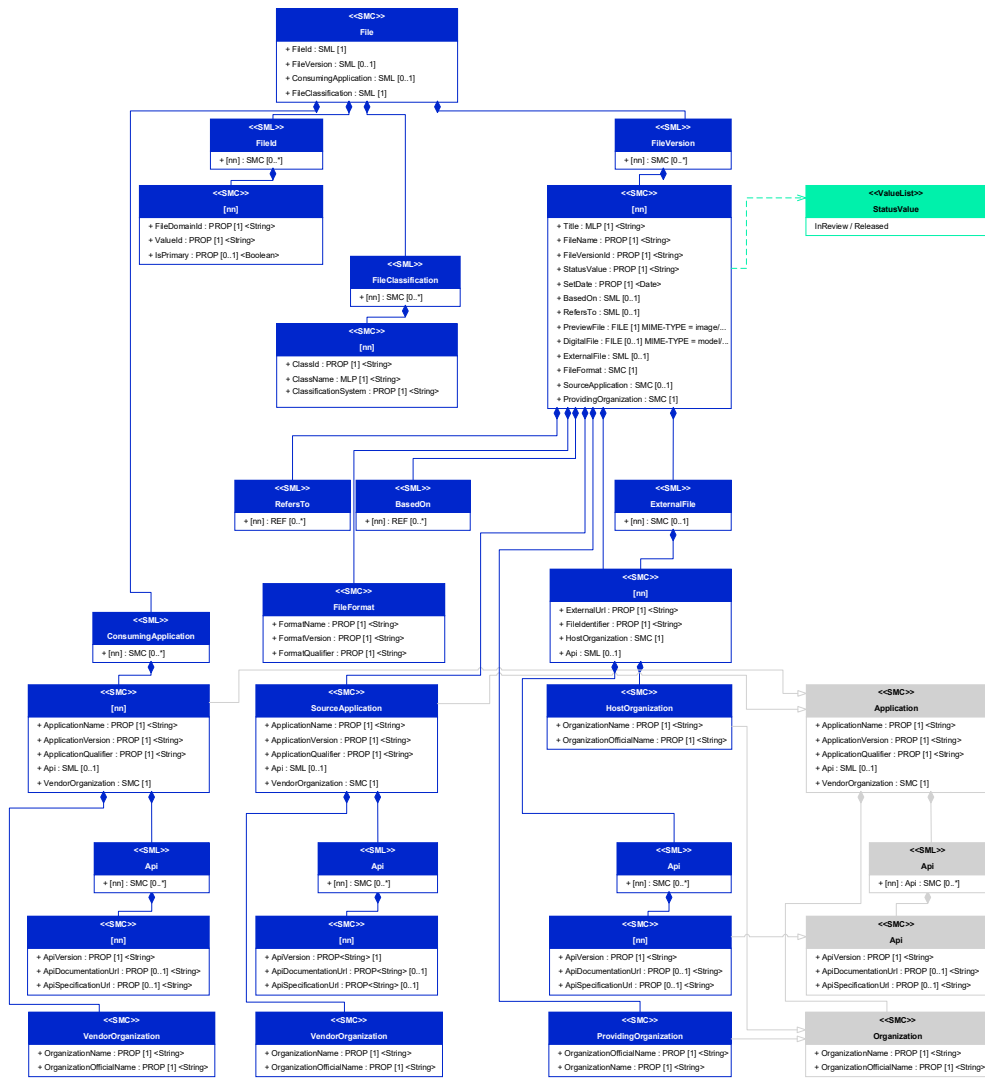

Figure 9: [SMC] File

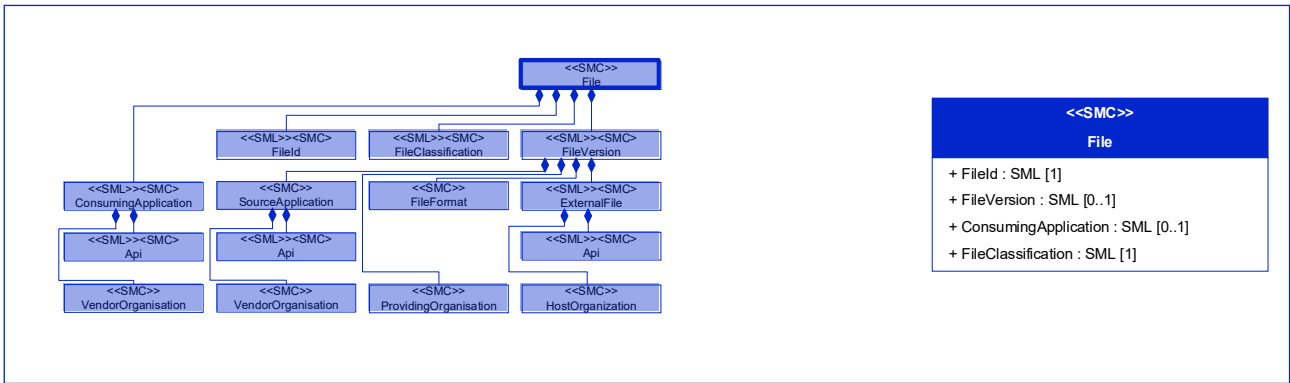

Figure 10: [SMC] File

Table 4: [SMC] File

<b>idShort:</b>	File		
<b>Class:</b>	SubmodelElementCollection [SMC]		
<b>semanticId:</b>	[IRI] <a href="https://admin-shell.io/idta/Models3D/Model3D/File/1/0">https://admin-shell.io/idta/Models3D/Model3D/File/1/0</a>		
<b>Parent:</b>	[IRI] <a href="https://admin-shell.io/idta/Models3D/Model3D/1/0">https://admin-shell.io/idta/Models3D/Model3D/1/0</a> Model3D		
<b>Explanation:</b>	Information about the model file entity. Contains the 3D model file, or external link to it.		
<b>[SME type]</b>	<b>semanticId = [idType]value</b>	<b>[valueType]</b>	<b>card.</b>
<b>idShort</b>	<b>Description@en</b>	<b>example</b>	
[SML][SMC] FileId	[IRI] <a href="https://admin-shell.io/idta/Models3D/Model3D/File/FileId/1/0">https://admin-shell.io/idta/Models3D/Model3D/File/FileId/1/0</a>  List of file identifiers for the file. One ID in this collection should be used as a preferred ID (see isPrimary below).	[n/a]	1
[SML][SMC] FileVersion	[IRI] <a href="https://admin-shell.io/idta/Models3D/Model3D/File/FileVersion/1/0">https://admin-shell.io/idta/Models3D/Model3D/File/FileVersion/1/0</a>  Information elements of file version entities.	[n/a]	0..1
[SML][SMC] ConsumingApplication	[IRI] <a href="https://admin-shell.io/idta/Models3D/Model3D/File/ConsumingApplication/1/0">https://admin-shell.io/idta/Models3D/Model3D/File/ConsumingApplication/1/0</a>  List of information about the intended consuming applications of the 3D model.	[n/a]	0..1
[SML][SMC] FileClassification	[IRI] <a href="https://admin-shell.io/idta/Models3D/Model3D/File/FileClassification/1/0">https://admin-shell.io/idta/Models3D/Model3D/File/FileClassification/1/0</a>  List of information for describing the classification of the file according to ClassificationSystems.	[n/a]	1

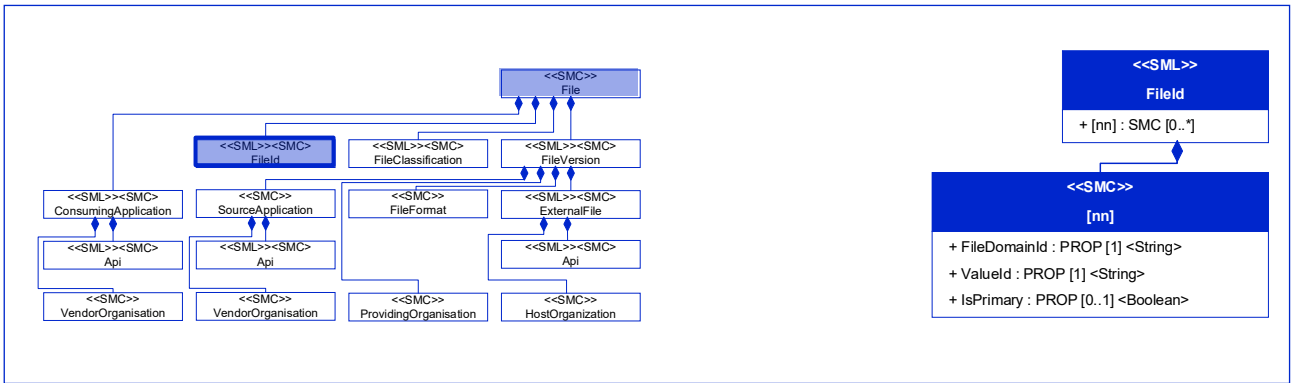

Figure 11: [SML][SMC] FileId

Table 5: [SML][SMC] FileId

<b>idShort:</b>	FileId		
<b>Class:</b>	SubmodelElementList that contains SubmodelElementCollections [SMC]		
<b>semanticId:</b>	[IRI] <a href="https://admin-shell.io/idta/Models3D/Model3D/File/FileId/1/0">https://admin-shell.io/idta/Models3D/Model3D/File/FileId/1/0</a>		
<b>Parent:</b>	[IRI] <a href="https://admin-shell.io/idta/Models3D/Model3D/File/1/0">https://admin-shell.io/idta/Models3D/Model3D/File/1/0</a> File		
<b>Explanation:</b>	List of file identifiers for the file. One ID in this collection should be used as a preferred ID (see isPrimary below).		
<b>[SME type]</b>	<b>semanticId = [idType]value</b>	<b>[valueType]</b>	<b>card.</b>
<b>idShort</b>	<b>Description@en</b>	<b>example</b>	
[Prop] FileDomainId	[IRI] <a href="https://admin-shell.io/idta/Models3D/Model3D/File/FileId/FileDomainId/1/0">https://admin-shell.io/idta/Models3D/Model3D/File/FileId/FileDomainId/1/0</a>  Identification of the domain in which the given ValueId is unique. The domain ID can be e.g. the name or acronym of the providing organization.	[String]	1
[Prop] ValueId	[IRI] <a href="https://admin-shell.io/idta/Models3D/Model3D/File/FileId/ValueId/1/0">https://admin-shell.io/idta/Models3D/Model3D/File/FileId/ValueId/1/0</a>  Identification value of the file within a given domain, e.g. the providing organization.	[String]	1
[Prop] IsPrimary	[IRI] <a href="https://admin-shell.io/idta/Models3D/Model3D/File/FileId/IsPrimary/1/0">https://admin-shell.io/idta/Models3D/Model3D/File/FileId/IsPrimary/1/0</a>  Flag indicating that a FileId within a collection of at least two FileIds is the 'primary' identifier for the document. This is the preferred ID of the document (commonly from the point of view of the owner of the asset).	[Boolean]	0..1

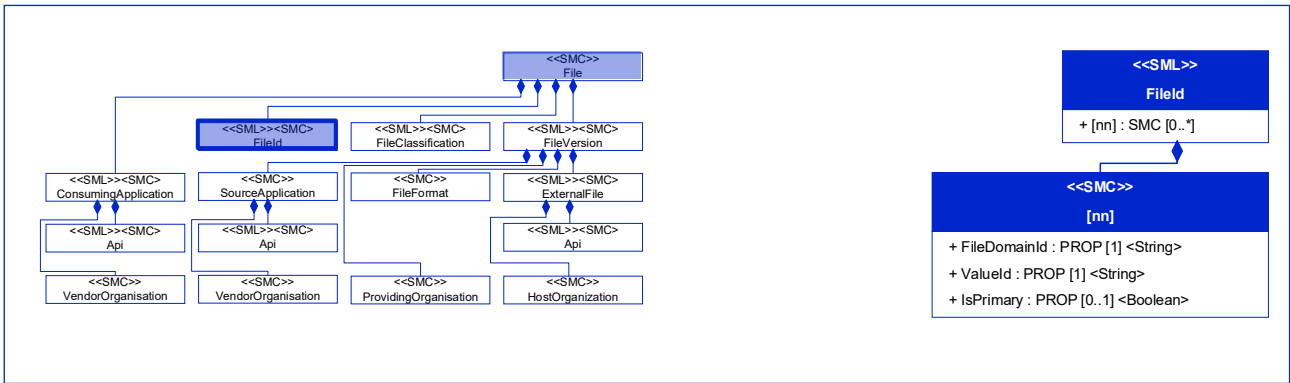

Figure 12: [Prop] FileDomainId

Table 6: [Prop] FileDomainId

<b>idShort:</b>	FileDomainId
<b>Class:</b>	Property [Prop] [String]
<b>semanticId:</b>	[IRI] <a href="https://admin-shell.io/idta/Models3D/Model3D/File/FileId/FileDomainId/1/0">https://admin-shell.io/idta/Models3D/Model3D/File/FileId/FileDomainId/1/0</a>
<b>Parent:</b>	[IRI] <a href="https://admin-shell.io/idta/Models3D/Model3D/File/FileId1/0">https://admin-shell.io/idta/Models3D/Model3D/File/FileId1/0</a> FileId
<b>Explanation:</b>	Identification of the domain in which the given ValueId is unique. The domain ID can be e.g. the name or acronym of the providing organization.

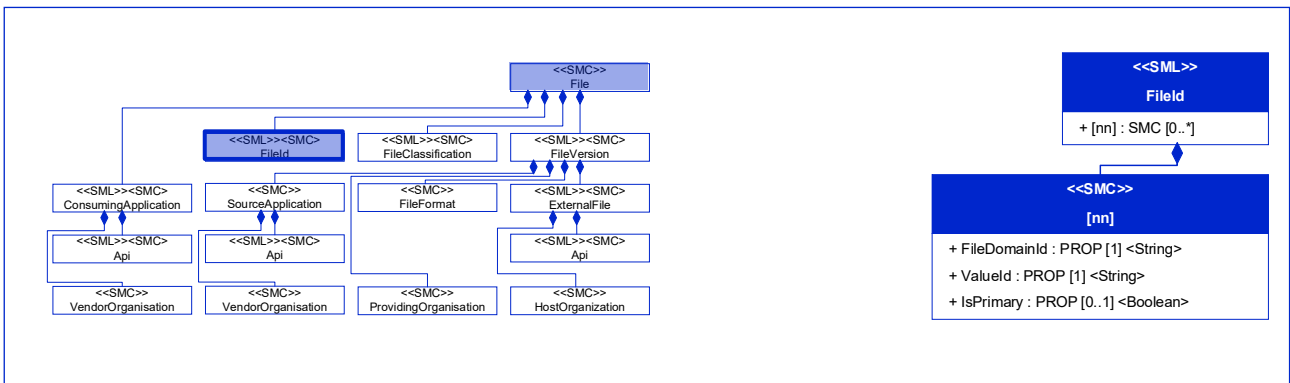

Figure 13: [Prop] ValueId

Table 7: [Prop] ValueId

<b>idShort:</b>	ValueId
<b>Class:</b>	Property [Prop] [String]
<b>semanticId:</b>	[IRI] <a href="https://admin-shell.io/idta/Models3D/Model3D/File/FileId/ValueId/1/0">https://admin-shell.io/idta/Models3D/Model3D/File/FileId/ValueId/1/0</a>
<b>Parent:</b>	[IRI] <a href="https://admin-shell.io/idta/Models3D/Model3D/File/FileId1/0">https://admin-shell.io/idta/Models3D/Model3D/File/FileId1/0</a> FileId
<b>Explanation:</b>	Identification value of the file within a given domain, e.g. the providing organization.

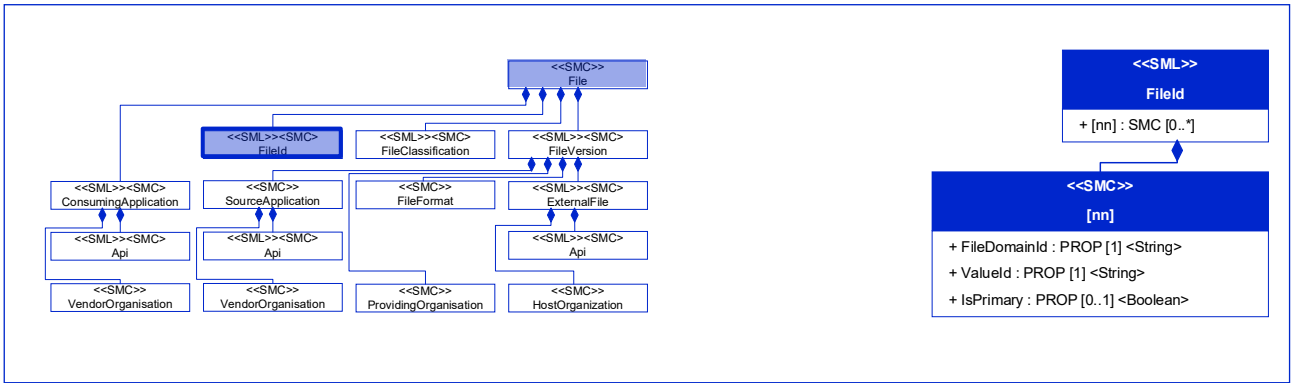

Figure 14: [Prop] IsPrimary

Table 8: [Prop] IsPrimary

<b>idShort:</b>	IsPrimary
<b>Class:</b>	Property [Prop] [Boolean]
<b>semanticId:</b>	[IRI] <a href="https://admin-shell.io/idta/Models3D/Model3D/File/FileId/isPrimary/1/0">https://admin-shell.io/idta/Models3D/Model3D/File/FileId/isPrimary/1/0</a>
<b>Parent:</b>	[IRI] <a href="https://admin-shell.io/idta/Models3D/Model3D/File/FileId/1/0">https://admin-shell.io/idta/Models3D/Model3D/File/FileId/1/0</a> FileId
<b>Explanation:</b>	Flag indicating that a FileId within a collection of at least two FileIds is the 'primary' identifier for the document. This is the preferred ID of the document (commonly from the point of view of the owner of the asset).

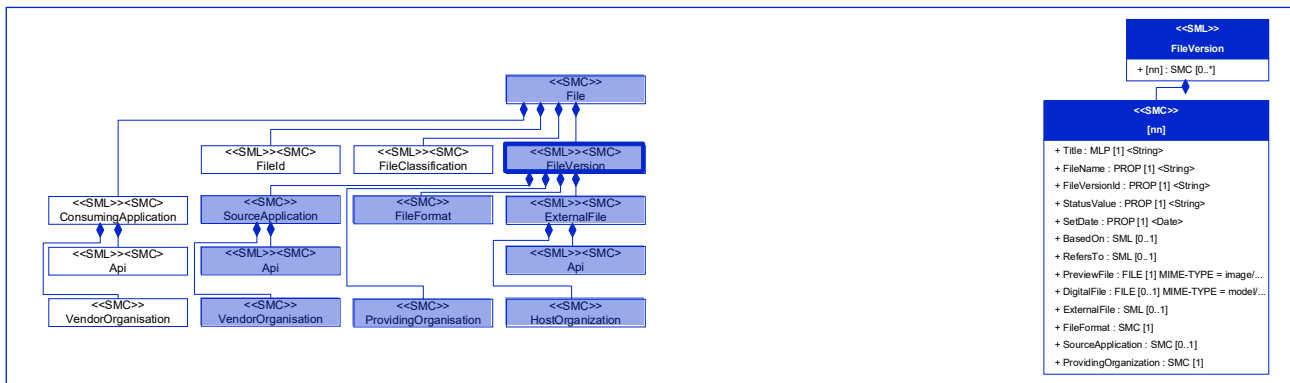

Figure 15: [SML][SMC] FileVersion

Table 9: [SML][SMC] FileVersion

<b>idShort:</b>	FileVersion		
<b>Class:</b>	SubmodelElementList [SML] that contains SubmodelElementCollections [SMC]		
<b>semanticId:</b>	[IRI] <a href="https://admin-shell.io/idta/Models3D/Model3D/File/FileVersion/1/0">https://admin-shell.io/idta/Models3D/Model3D/File/FileVersion/1/0</a>		
<b>Parent:</b>	[IRI] <a href="https://admin-shell.io/idta/Models3D/Model3D/File/1/0">https://admin-shell.io/idta/Models3D/Model3D/File/1/0</a> File		
<b>Explanation:</b>	List of information elements of file version entities.		
<b>[SME type]</b>	<b>semanticId = [idType]value</b>	<b>[valueType]</b>	<b>card.</b>
<b>idShort</b>	<b>Description@en</b>	<b>example</b>	
[MLP] Title	[IRI] <a href="https://admin-shell.io/idta/Models3D/Model3D/File/FileVersion/Title/1/0">https://admin-shell.io/idta/Models3D/Model3D/File/FileVersion/Title/1/0</a>  List of language-dependent titles of the file.	[String]  Exemplary title@en Deutscher Titel@de	1
[Prop] FileName	[IRI] <a href="https://admin-shell.io/idta/Models3D/Model3D/File/FileVersion/FileName/1/0">https://admin-shell.io/idta/Models3D/Model3D/File/FileVersion/FileName/1/0</a>  Name of the file.	[String]  example-name	1
[Prop] FileVersionId	[IRI] <a href="https://admin-shell.io/idta/Models3D/Model3D/File/FileVersion/FileVersionId/1/0">https://admin-shell.io/idta/Models3D/Model3D/File/FileVersion/FileVersionId/1/0</a>  Unambiguous identification number of a FileVersion. Recommended versioning scheme is integer, point separated: MAJOR.MINOR.REVISION.	[String]  4.2.1	1
[Prop] StatusValue	[IRI] <a href="https://admin-shell.io/idta/Models3D/Model3D/File/FileVersion/StatusValue/1/0">https://admin-shell.io/idta/Models3D/Model3D/File/FileVersion/StatusValue/1/0</a>  Each file version represents a point in time in the file lifecycle. This status value refers to the milestones in the file lifecycle.  Use ValueList – StatusValue	[String]  Released	1

[Prop] SetDate	[IRI] <a href="https://admin-shell.io/idta/Models3D/Model3D/File/FileVersion/SetDate/1/0">https://admin-shell.io/idta/Models3D/Model3D/File/FileVersion/SetDate/1/0</a> Date when the document status was set. Format is YYYY-MM-dd.	[Date] 2020-02-06	1
[SML][Ref] BasedOn	[IRI] <a href="https://admin-shell.io/idta/Models3D/Model3D/File/FileVersion/BasedOn/1/0">https://admin-shell.io/idta/Models3D/Model3D/File/FileVersion/BasedOn/1/0</a> List of BasedOn relationships to other 3D Files or 3D FileVersion. Typically states that the content of the file is based on another file. Both have a strong relationship. Constraint: reference targets a [SMC] "File" or a [SMC] "FileVersion".	[n/a]	0..1
[SML][Ref] RefersTo	[IRI] <a href="https://admin-shell.io/idta/Models3D/Model3D/File/FileVersion/RefersTo/1/0">https://admin-shell.io/idta/Models3D/Model3D/File/FileVersion/RefersTo/1/0</a> List of generic RefersTo relationships to other 3D Files or 3D FileVersions. They have a loose relationship. Constraint: reference targets a [SMC] "File" or a [SMC] "FileVersion".	[n/a]	0..1
[File] PreviewFile	[IRI] <a href="https://admin-shell.io/idta/Models3D/Model3D/File/FileVersion/PreviewFile/1/0">https://admin-shell.io/idta/Models3D/Model3D/File/FileVersion/PreviewFile/1/0</a> Provides a preview image of the DocumentVersion, e.g. first page, in a commonly used image format and in low resolution (< 512 x 512 pixels). Constraint: the MIME-Type needs to match the file type. Allowed file types are JPG, PNG, BMP.	[MIME-Type = image/...]	1
[File] DigitalFile	[IRI] <a href="https://admin-shell.io/idta/Models3D/Model3D/File/FileVersion/DigitalFile/1/0">https://admin-shell.io/idta/Models3D/Model3D/File/FileVersion/DigitalFile/1/0</a> MIME-Type, file name, and file contents given by the File SubmodelElement. Preferable use "MIME-Type = model/...". If file type is not defined, use "MIME-Type = application/octet-stream"	[MIME-Type = ...]	0..1
[SML] ExternalFile	[IRI] <a href="https://admin-shell.io/idta/Models3D/Model3D/File/FileVersion/ExternalFile/1/0">https://admin-shell.io/idta/Models3D/Model3D/File/FileVersion/ExternalFile/1/0</a> Contains information to retrieve the file from an external source.	[n/a]	0..1
[SMC] FileFormat	[IRI] <a href="https://admin-shell.io/idta/Models3D/Model3D/File/FileVersion/FileFormat/1/0">https://admin-shell.io/idta/Models3D/Model3D/File/FileVersion/FileFormat/1/0</a> Contains information about the file format.	[n/a]	1

[SMC] SourceApplication	[IRI] <a href="https://admin-shell.io/idta/Models3D/Model3D/File/FileVersion/SourceApplication/1/0">https://admin-shell.io/idta/Models3D/Model3D/File/FileVersion/SourceApplication/1/0</a>  Information about the source application the 3D model originated from.	[n/a]	0..1
[SMC] ProvidingOrganization	[IRI] <a href="https://admin-shell.io/idta/Models3D/Model3D/File/FileVersion/ProvidingOrganization/1/0">https://admin-shell.io/idta/Models3D/Model3D/File/FileVersion/ProvidingOrganization/1/0</a>  Information about the model providing organization.	[n/a]	1

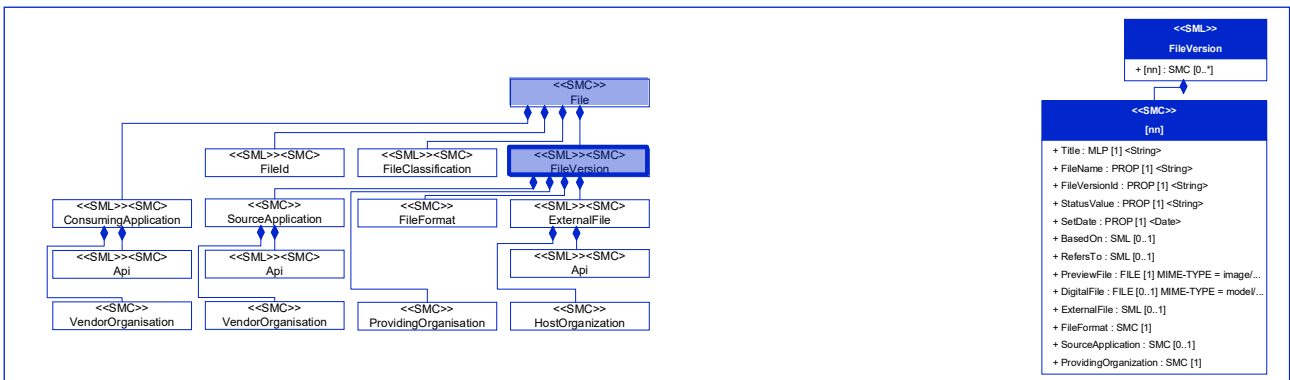

Figure 16: [MLP] Title

Table 10: [MLP] Title

<b>idShort:</b>	Title
<b>Class:</b>	MultiLanguageProperty [MLP] [String]
<b>semanticId:</b>	[IRI] <a href="https://admin-shell.io/idta/Models3D/Model3D/File/FileVersion/Title/1/0">https://admin-shell.io/idta/Models3D/Model3D/File/FileVersion/Title/1/0</a>
<b>Parent:</b>	[IRI] <a href="https://admin-shell.io/idta/Models3D/Model3D/File/FileVersion/1/0">https://admin-shell.io/idta/Models3D/Model3D/File/FileVersion/1/0</a> FileVersion
<b>Explanation:</b>	List of language-dependent titles of the file.

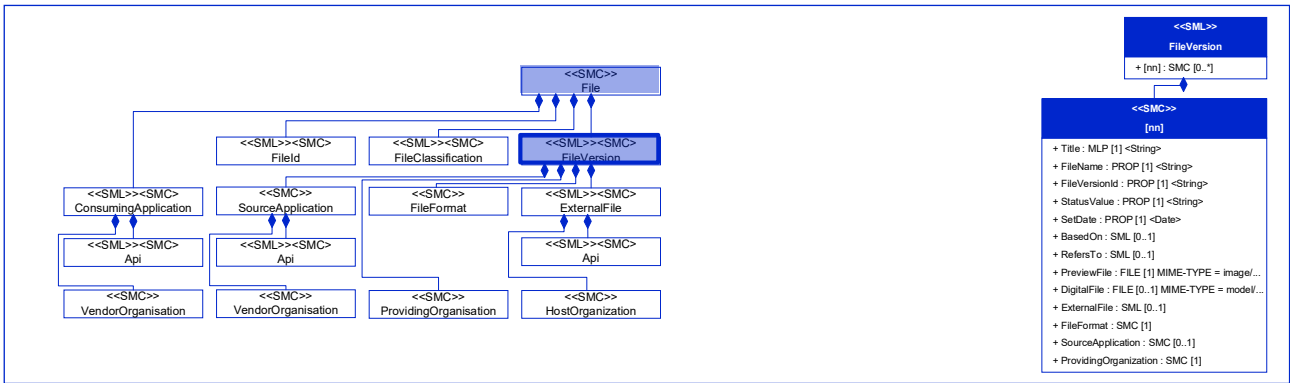

Figure 17: [Prop] FileName

Table 11: [Prop] FileName

<b>idShort:</b>	FileName
<b>Class:</b>	Property [Prop] [String]
<b>semanticId:</b>	[IRI] <a href="https://admin-shell.io/idta/Models3D/Model3D/File/FileVersion/FileName/1/0">https://admin-shell.io/idta/Models3D/Model3D/File/FileVersion/FileName/1/0</a>
<b>Parent:</b>	[IRI] <a href="https://admin-shell.io/idta/Models3D/Model3D/File/FileVersion/1/0">https://admin-shell.io/idta/Models3D/Model3D/File/FileVersion/1/0</a> FileVersion
<b>Explanation:</b>	Name of the file.

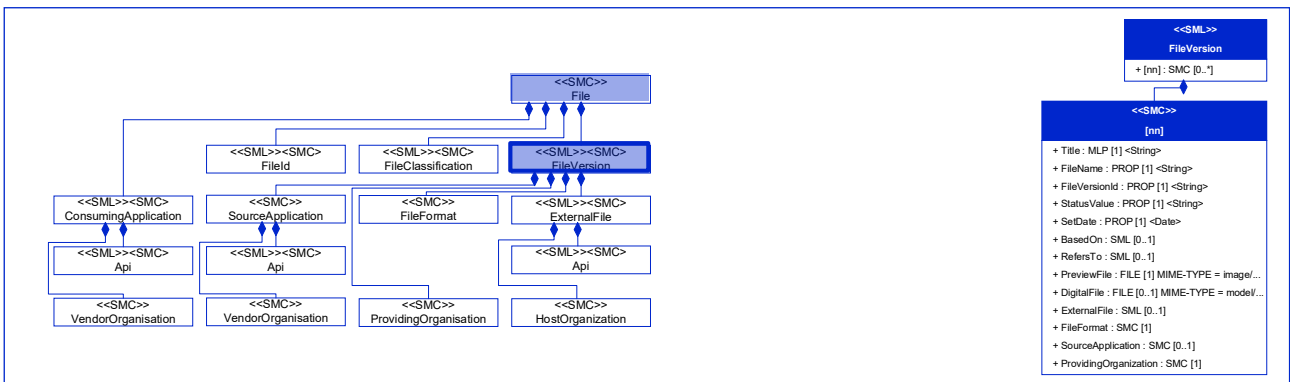

Figure 18: [Prop] FileVersionId

Table 12: [Prop] FileVersionId

<b>idShort:</b>	FileVersionId
<b>Class:</b>	Property [Prop] [Boolean]
<b>semanticId:</b>	[IRI] <a href="https://admin-shell.io/idta/Models3D/Model3D/File/FileVersion/FileVersionId/1/0">https://admin-shell.io/idta/Models3D/Model3D/File/FileVersion/FileVersionId/1/0</a>
<b>Parent:</b>	[IRI] <a href="https://admin-shell.io/idta/Models3D/Model3D/File/FileVersion/1/0">https://admin-shell.io/idta/Models3D/Model3D/File/FileVersion/1/0</a> FileVersion
<b>Explanation:</b>	Unambiguous identification number of a FileVersion. Recommended versioning scheme is integer, point separated: MAJOR.MINOR.REVISION.

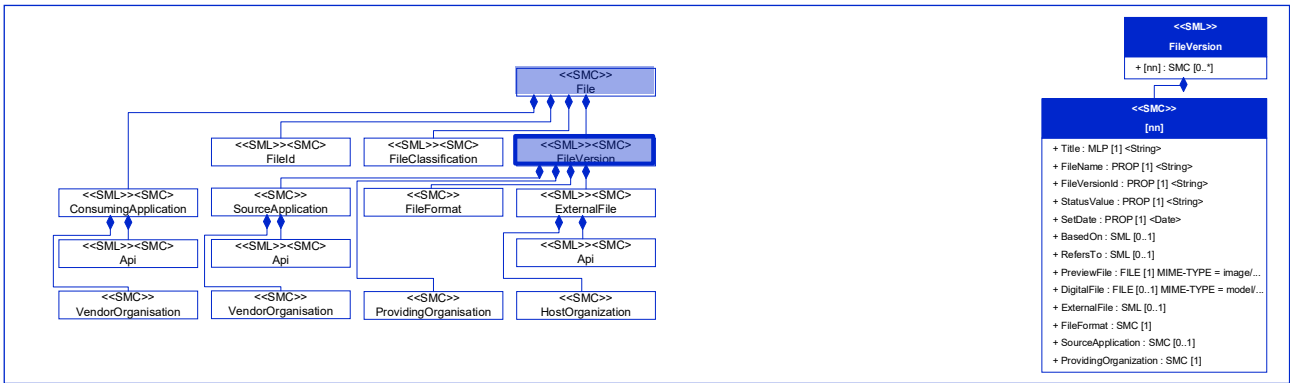

Figure 19: [Prop] StatusValue

Table 13: [Prop] StatusValue

<b>idShort:</b>	StatusValue
<b>Class:</b>	Property [Prop] [String]
<b>semanticId:</b>	[IRI] <a href="https://admin-shell.io/idta/Models3D/Model3D/File/FileVersion/StatusValue/1/0">https://admin-shell.io/idta/Models3D/Model3D/File/FileVersion/StatusValue/1/0</a>
<b>Parent:</b>	[IRI] <a href="https://admin-shell.io/idta/Models3D/Model3D/File/FileVersion/1/0">https://admin-shell.io/idta/Models3D/Model3D/File/FileVersion/1/0</a> FileVersion
<b>Explanation:</b>	Each file version represents a point in time in the file lifecycle. This status value refers to the milestones in the file lifecycle. Use ValueList – StatusValue

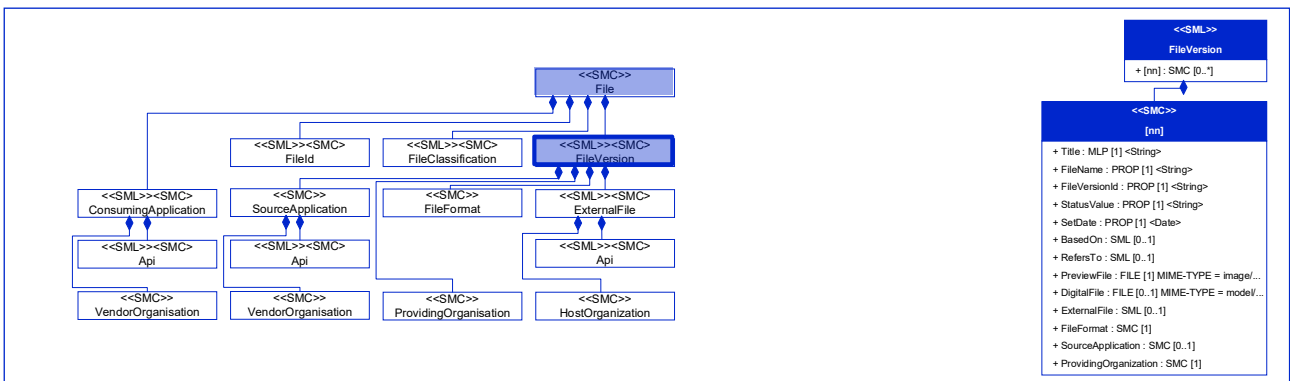

Figure 20: [Prop] SetDate

Table 14: [Prop] SetDate

<b>idShort:</b>	SetDate
<b>Class:</b>	Property [Prop] [Date]
<b>semanticId:</b>	[IRI] <a href="https://admin-shell.io/idta/Models3D/Model3D/File/FileVersion/SetDate/1/0">https://admin-shell.io/idta/Models3D/Model3D/File/FileVersion/SetDate/1/0</a>
<b>Parent:</b>	[IRI] <a href="https://admin-shell.io/idta/Models3D/Model3D/File/FileVersion/1/0">https://admin-shell.io/idta/Models3D/Model3D/File/FileVersion/1/0</a> FileVersion
<b>Explanation:</b>	Date when the document status was set. Format is YYYY-MM-dd.

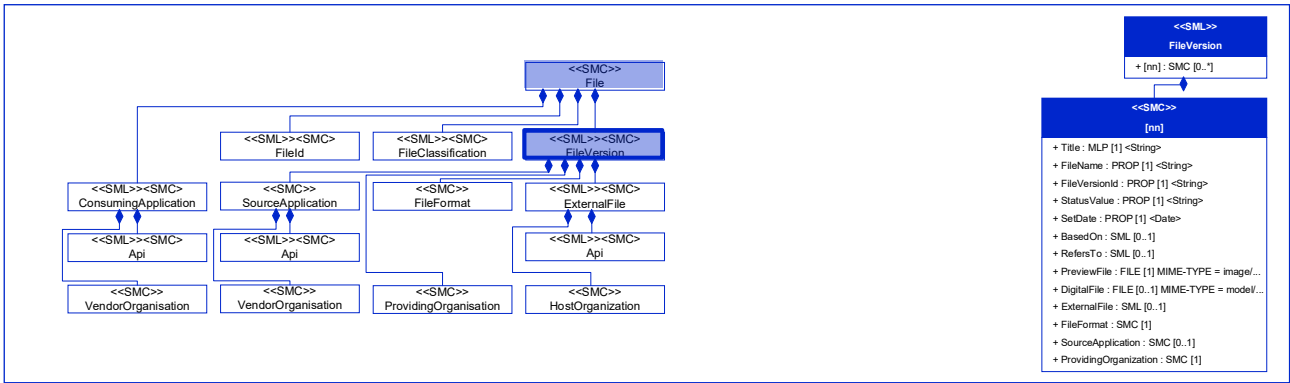

Figure 21: [SML][Ref] BasedOn

Table 15: [SML][Ref] BasedOn

<b>idShort:</b>	BasedOn
<b>Class:</b>	SubmodelElementList [SML] that contains References [Ref]
<b>semanticId:</b>	[IRI] <a href="https://admin-shell.io/idta/Models3D/Model3D/File/FileVersion/BasedOn/1/0">https://admin-shell.io/idta/Models3D/Model3D/File/FileVersion/BasedOn/1/0</a>
<b>Parent:</b>	[IRI] <a href="https://admin-shell.io/idta/Models3D/Model3D/File/FileVersion/1/0">https://admin-shell.io/idta/Models3D/Model3D/File/FileVersion/1/0</a> FileVersion
<b>Explanation:</b>	List of BasedOn relationships to other 3D Files or 3D FileVersions. Typically states that the content of the file is based on another file. Both have a strong relationship. Constraint: reference targets a [SMC] "File" or a [SMC] "FileVersion".

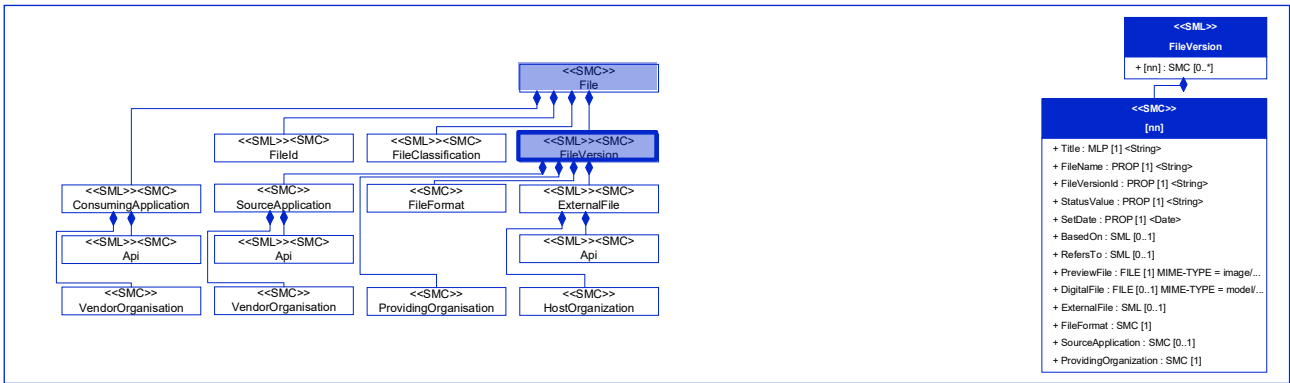

Figure 22: [SML][Ref] RefersTo

Table 16: [SML][Ref] RefersTo

<b>idShort:</b>	RefersTo
<b>Class:</b>	SubmodelElementList [SML] that contains References [Ref]
<b>semanticId:</b>	[IRI] <a href="https://admin-shell.io/idta/Models3D/Model3D/File/FileVersion/RefersTo/1/0">https://admin-shell.io/idta/Models3D/Model3D/File/FileVersion/RefersTo/1/0</a>
<b>Parent:</b>	[IRI] <a href="https://admin-shell.io/idta/Models3D/Model3D/File/FileVersion/1/0">https://admin-shell.io/idta/Models3D/Model3D/File/FileVersion/1/0</a> FileVersion
<b>Explanation:</b>	List of generic RefersTo relationships to other 3D Files or 3D FileVersions. They have a loose relationship. Constraint: reference targets a [SMC] "File" or a [SMC] "FileVersion".

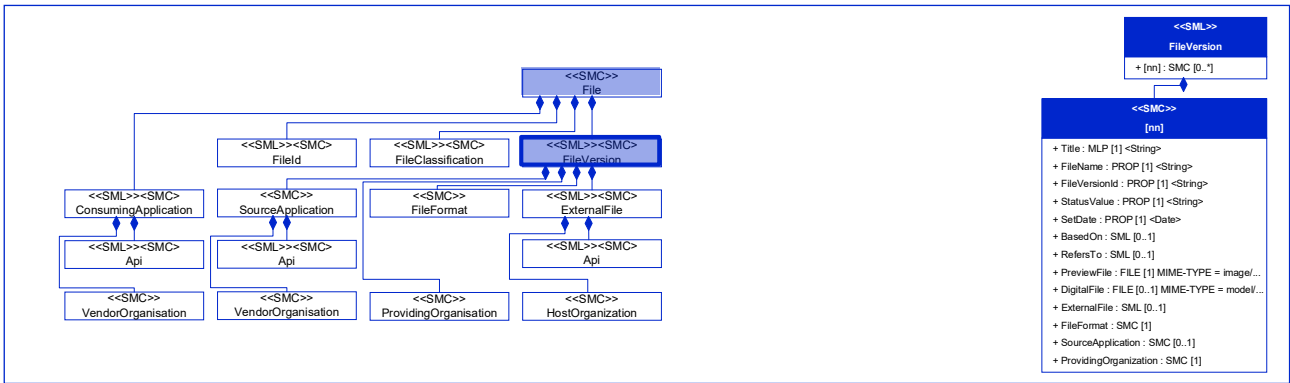

Figure 23: [File] PreviewFile

Table 17: [File] PreviewFile

<b>idShort:</b>	PreviewFile
<b>Class:</b>	File [File] [MIME-Type = image/...]
<b>semanticId:</b>	[IRI] <a href="https://admin-shell.io/idta/Models3D/Model3D/File/FileVersion/PreviewFile/1/0">https://admin-shell.io/idta/Models3D/Model3D/File/FileVersion/PreviewFile/1/0</a>
<b>Parent:</b>	[IRI] <a href="https://admin-shell.io/idta/Models3D/Model3D/File/FileVersion/1/0">https://admin-shell.io/idta/Models3D/Model3D/File/FileVersion/1/0</a> FileVersion
<b>Explanation:</b>	Provides a preview image of the DocumentVersion, e.g. first page, in a commonly used image format and in low resolution (< 512 x 512 pixels).  Constraint: the MIME-Type needs to match the file type. Allowed file types are JPG, PNG, BMP.

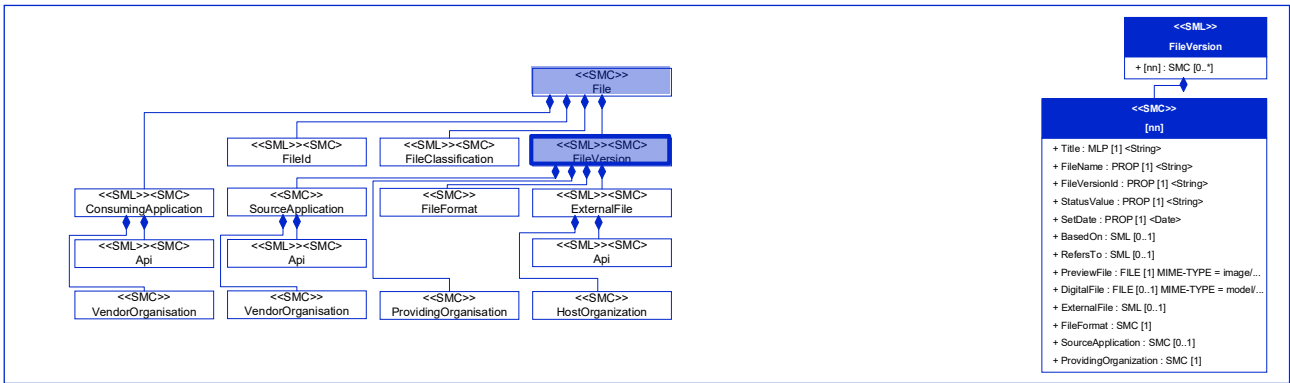

Figure 24: [File] DigitalFile

Table 18: [File] DigitalFile

<b>idShort:</b>	DigitalFile
<b>Class:</b>	File [File] [MIME-Type = ...]
<b>semanticId:</b>	[IRI] <a href="https://admin-shell.io/idta/Models3D/Model3D/File/FileVersion/DigitalFile/1/0">https://admin-shell.io/idta/Models3D/Model3D/File/FileVersion/DigitalFile/1/0</a>
<b>Parent:</b>	[IRI] <a href="https://admin-shell.io/idta/Models3D/Model3D/File/FileVersion/1/0">https://admin-shell.io/idta/Models3D/Model3D/File/FileVersion/1/0</a> FileVersion
<b>Explanation:</b>	MIME-Type, file name, and file contents given by the File SubmodelElement. Preferable use “MIME-Type = model/...”. If file type is not defined, use “MIME-Type = application/octet-stream”

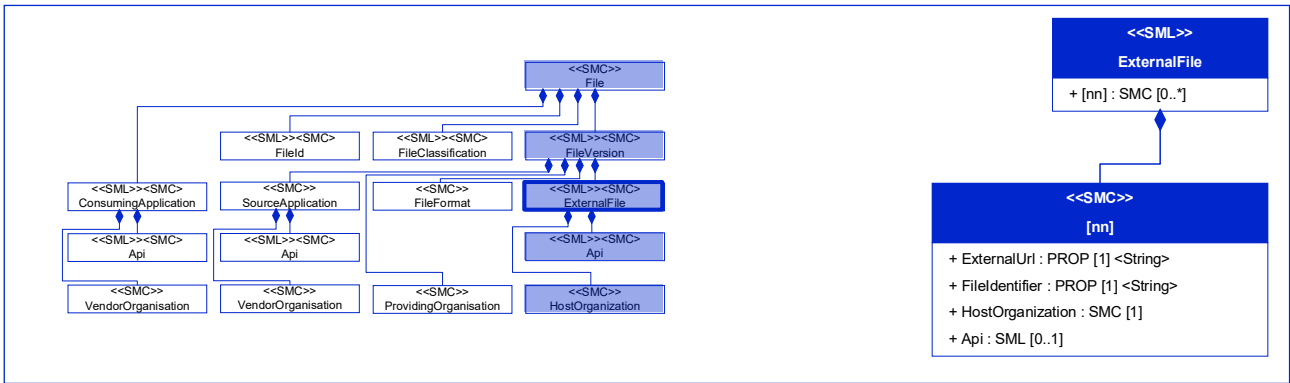

Figure 25: [SML][SMC] ExternalFile

Table 19: [SML][SMC] ExternalFile

<b>idShort:</b>	ExternalFile		
<b>Class:</b>	SubmodelElementList [SML] that contains SubmodelElementCollections [SMC]		
<b>semanticId:</b>	[IRI] <a href="https://admin-shell.io/idta/Models3D/Model3D/File/FileVersion/ExternalFile/1/0">https://admin-shell.io/idta/Models3D/Model3D/File/FileVersion/ExternalFile/1/0</a>		
<b>Parent:</b>	[IRI] <a href="https://admin-shell.io/idta/Models3D/Model3D/File/FileVersion/1/0">https://admin-shell.io/idta/Models3D/Model3D/File/FileVersion/1/0</a> FileVersion		
<b>Explanation:</b>	List of information to retrieve the file from an external host.		
<b>[SME type]</b>	<b>semanticId = [idType]value</b>	<b>[valueType]</b>	<b>card.</b>
<b>idShort</b>	<b>Description@en</b>	<b>example</b>	
[Prop] ExternalUrl	[IRI] <a href="https://admin-shell.io/idta/Models3D/Model3D/File/FileVersion/ExternalFile/ExternalUrl/1/0">https://admin-shell.io/idta/Models3D/Model3D/File/FileVersion/ExternalFile/ExternalUrl/1/0</a>  Call link to an external file host. If applicable with identifier of the asset inside the URL.	[String]  https://admin-shell-io.com/5001/	1
[Prop] FileIdentifier	[IRI] <a href="https://admin-shell.io/idta/Models3D/Model3D/File/FileVersion/ExternalFile/FileIdentifier/1/0">https://admin-shell.io/idta/Models3D/Model3D/File/FileVersion/ExternalFile/FileIdentifier/1/0</a>  Identifier of the file that is unique within the ExternalUrl domain.	[String]  https://boschrexroth.com/ids/aas?p=p652370&m=R90150807&s=1201694127	1
[SMC] HostOrganization	[IRI] <a href="https://admin-shell.io/idta/Models3D/Model3D/File/FileVersion/ExternalFile/HostOrganization/1/0">https://admin-shell.io/idta/Models3D/Model3D/File/FileVersion/ExternalFile/HostOrganization/1/0</a>  Information about the external file host organization.	[n/a]	1
[SML][SMC] Api	[IRI] <a href="https://admin-shell.io/idta/Models3D/Model3D/File/FileVersion/ExternalFile/Api/1/0">https://admin-shell.io/idta/Models3D/Model3D/File/FileVersion/ExternalFile/Api/1/0</a>  List of information about how the application programming interfaces (APIs) of the external file host is defined.	[n/a]	0..1

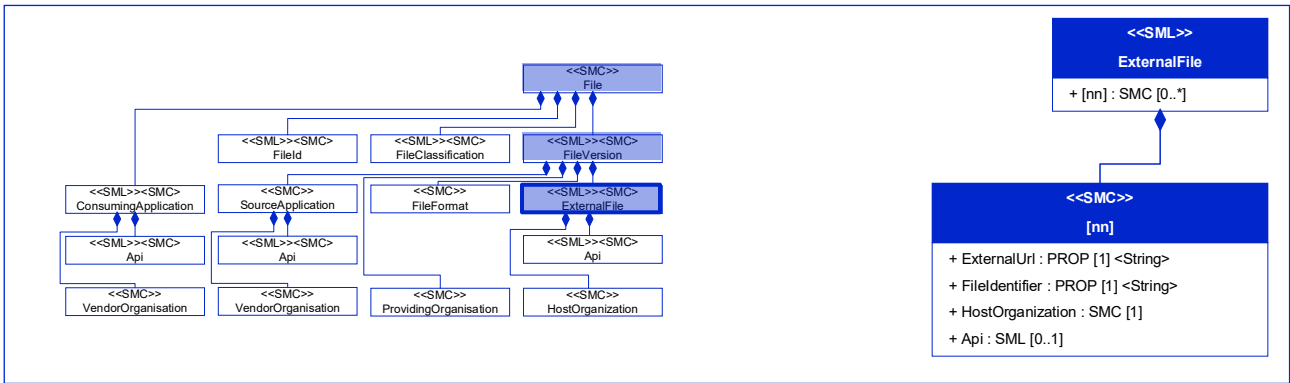

Figure 26: [Prop] ExternalUrl

Table 20: [Prop] ExternalUrl

<b>idShort:</b>	ExternalUrl
<b>Class:</b>	Property [Prop] [String]
<b>semanticId:</b>	[IRI] <a href="https://admin-shell.io/idta/Models3D/Model3D/File/FileVersion/ExternalFile/ExternalUrl/1/0">https://admin-shell.io/idta/Models3D/Model3D/File/FileVersion/ExternalFile/ExternalUrl/1/0</a>
<b>Parent:</b>	[IRI] <a href="https://admin-shell.io/idta/Models3D/Model3D/File/FileVersion/ExternalFile/1/0">https://admin-shell.io/idta/Models3D/Model3D/File/FileVersion/ExternalFile/1/0</a> ExternalFile
<b>Explanation:</b>	Call link to an external file host. If applicable with identifier of the asset inside the URL.

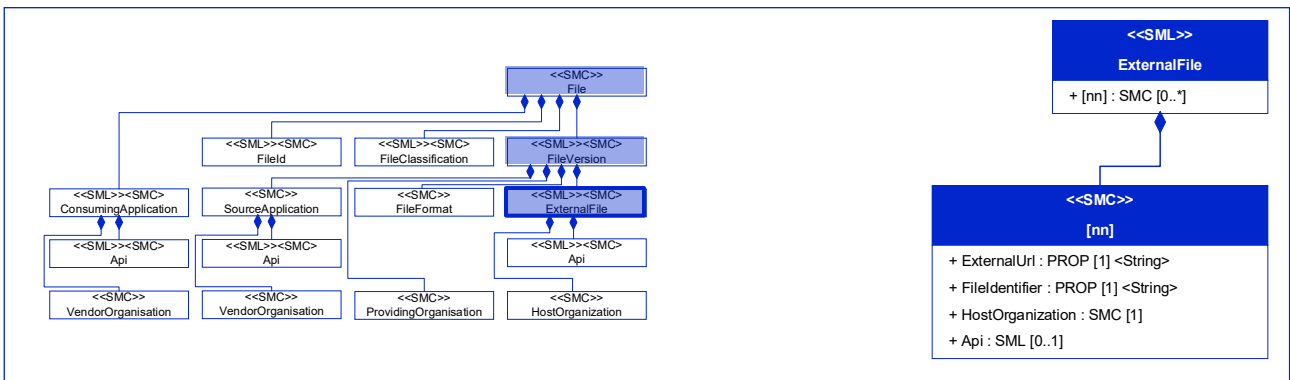

Figure 27: [Prop] FileIdentifier

Table 21: [Prop] FileIdentifier

<b>idShort:</b>	FileIdentifier
<b>Class:</b>	Property [Prop] [String]
<b>semanticId:</b>	[IRI] <a href="https://admin-shell.io/idta/Models3D/Model3D/File/FileVersion/ExternalFile/FileIdentifier/1/0">https://admin-shell.io/idta/Models3D/Model3D/File/FileVersion/ExternalFile/FileIdentifier/1/0</a>
<b>Parent:</b>	[IRI] <a href="https://admin-shell.io/idta/Models3D/Model3D/File/FileVersion/ExternalFile/1/0">https://admin-shell.io/idta/Models3D/Model3D/File/FileVersion/ExternalFile/1/0</a> ExternalFile
<b>Explanation:</b>	Identifier of the file that is unique within the ExternalUrl domain.

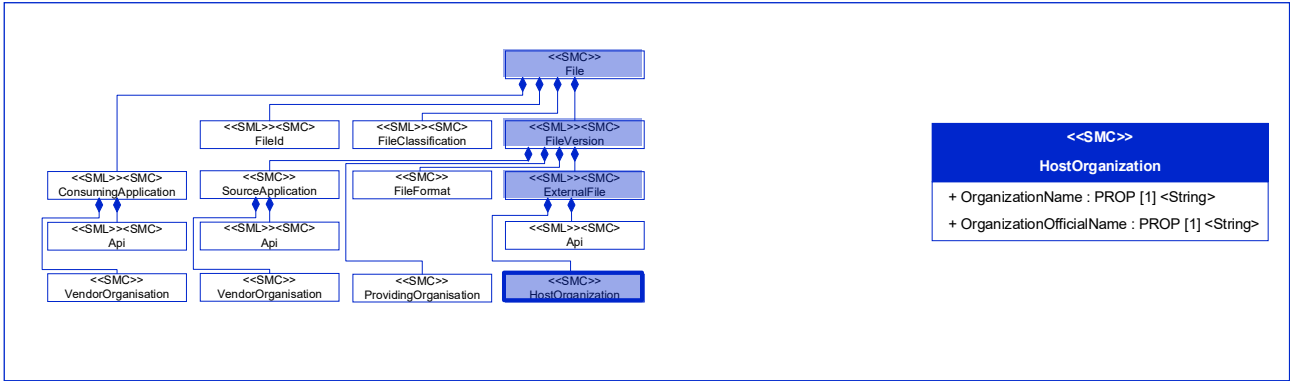

Figure 28: [SMC] HostOrganization

Table 22: [SMC] HostOrganization

<b>idShort:</b>	HostOrganization		
<b>Class:</b>	SubmodelElementCollection [SMC]		
<b>semanticId:</b>	[IRI] <a href="https://admin-shell.io/idta/Models3D/Model3D/File/FileVersion/ExternalFile/HostOrganization/1/0">https://admin-shell.io/idta/Models3D/Model3D/File/FileVersion/ExternalFile/HostOrganization/1/0</a>		
<b>Parent:</b>	[IRI] <a href="https://admin-shell.io/idta/Models3D/Model3D/File/FileVersion/ExternalFile/1/0">https://admin-shell.io/idta/Models3D/Model3D/File/FileVersion/ExternalFile/1/0</a> ExternalFile		
<b>Explanation:</b>	Information about the external file host organization.		
<b>[SME type]</b>	<b>semanticId = [idType]value</b>	<b>[valueType]</b>	<b>card.</b>
<b>idShort</b>	<b>Description@en</b>	<b>example</b>	
[Prop]	[IRI] <a href="https://admin-shell.io/idta/Models3D/Model3D/File/FileVersion/ExternalFile/HostOrganization/OrganizationName/1/0">https://admin-shell.io/idta/Models3D/Model3D/File/FileVersion/ExternalFile/HostOrganization/OrganizationName/1/0</a> OrganizationName Short name of the external file host organization.	[String] IDTA	1
[Prop]	[IRI] <a href="https://admin-shell.io/idta/Models3D/Model3D/File/FileVersion/ExternalFile/HostOrganization/OrganizationOfficialName/1/0">https://admin-shell.io/idta/Models3D/Model3D/File/FileVersion/ExternalFile/HostOrganization/OrganizationOfficialName/1/0</a> OrganizationOfficialName Official name of the external file host organization.	[String] Industrial Digital Twin Association e. V.	1

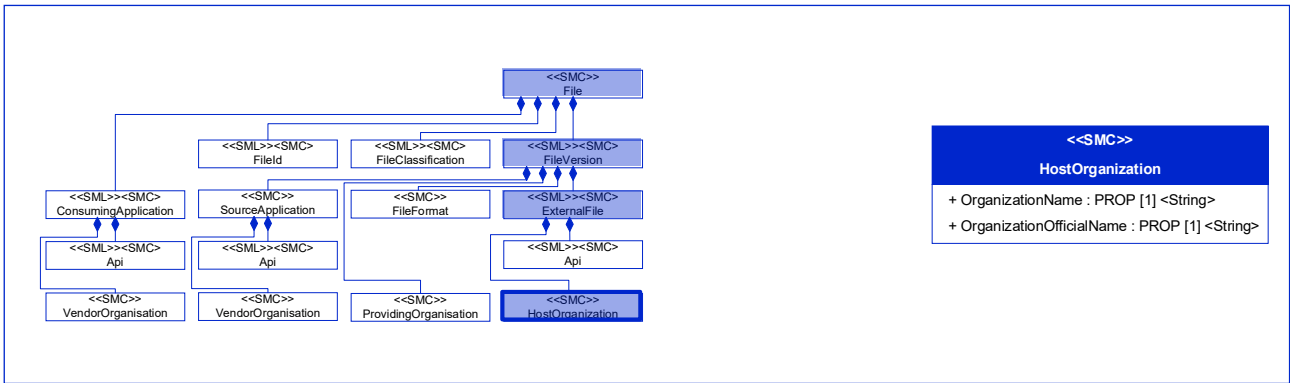

Figure 29: [Prop] OrganizationName

Table 23: [Prop] OrganizationName

<b>idShort:</b>	OrganizationName
<b>Class:</b>	Property [Prop] [String]
<b>semanticId:</b>	[IRI] <a href="https://admin-shell.io/idta/Models3D/Model3D/File/FileVersion/ExternalFile/HostOrganization/OrganizationName1/0">https://admin-shell.io/idta/Models3D/Model3D/File/FileVersion/ExternalFile/HostOrganization/OrganizationName1/0</a>
<b>Parent:</b>	[IRI] <a href="https://admin-shell.io/idta/Models3D/Model3D/File/FileVersion/ExternalFile/HostOrganization/1/0">https://admin-shell.io/idta/Models3D/Model3D/File/FileVersion/ExternalFile/HostOrganization/1/0</a> HostOrganization
<b>Explanation:</b>	Short name of the external file host organization.

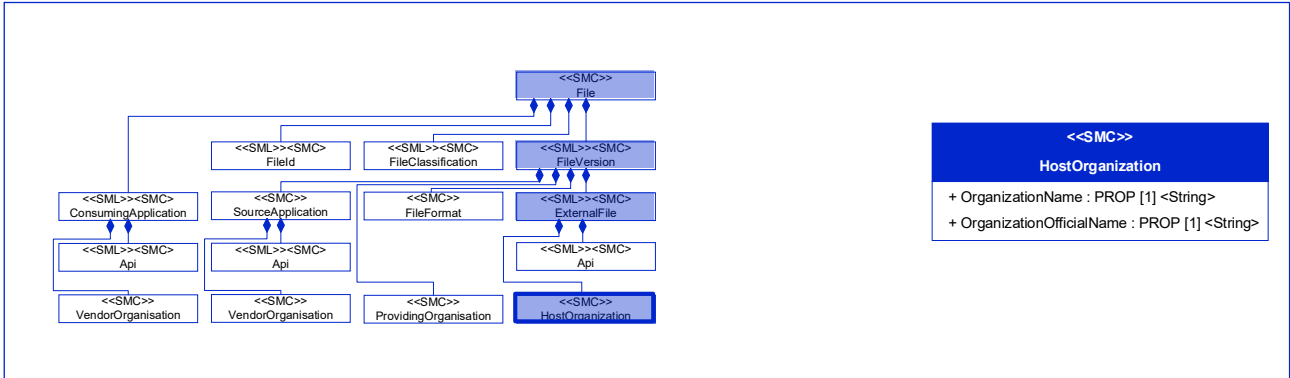

Figure 30: [Prop] OrganizationOfficialName

Table 24: [Prop] OrganizationOfficialName

<b>idShort:</b>	OrganizationOfficialName
<b>Class:</b>	Property [Prop] [String]
<b>semanticId:</b>	[IRI] <a href="https://admin-shell.io/idta/Models3D/Model3D/File/FileVersion/ExternalFile/HostOrganization/OrganizationOfficialName1/0">https://admin-shell.io/idta/Models3D/Model3D/File/FileVersion/ExternalFile/HostOrganization/OrganizationOfficialName1/0</a>
<b>Parent:</b>	[IRI] <a href="https://admin-shell.io/idta/Models3D/Model3D/File/FileVersion/ExternalFile/HostOrganization/1/0">https://admin-shell.io/idta/Models3D/Model3D/File/FileVersion/ExternalFile/HostOrganization/1/0</a> HostOrganization
<b>Explanation:</b>	Official name of the external file host organization.



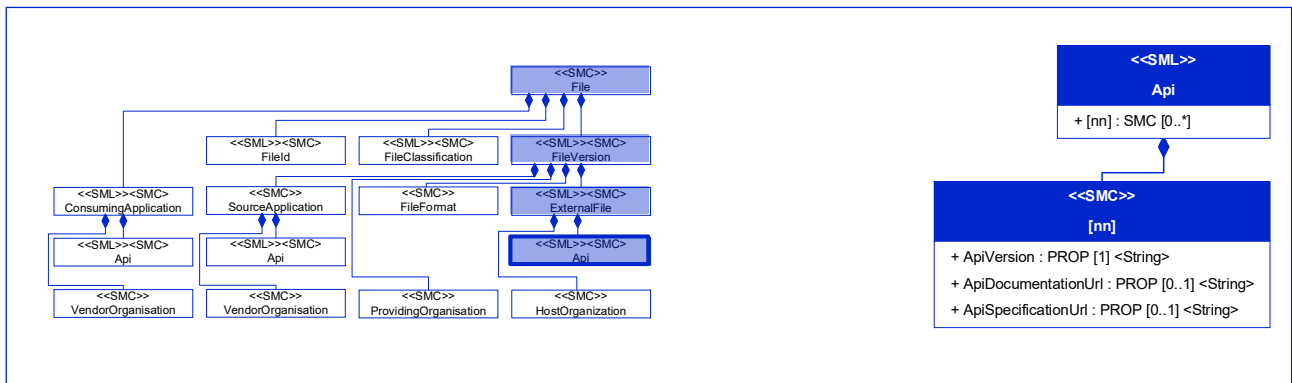

Figure 32: [Prop] ApiVersion

Table 26: [Prop] ApiVersion

<b>idShort:</b>	ApiVersion
<b>Class:</b>	Property [Prop] [String]
<b>semanticId:</b>	[[IRI] <a href="https://admin-shell.io/idta/Models3D/Model3D/File/FileVersion/ExternalFile/Api/ApiVersion/1/0">https://admin-shell.io/idta/Models3D/Model3D/File/FileVersion/ExternalFile/Api/ApiVersion/1/0</a>
<b>Parent:</b>	[IRI] <a href="https://admin-shell.io/idta/Models3D/Model3D/File/FileVersion/ExternalFile/Api/1/0">https://admin-shell.io/idta/Models3D/Model3D/File/FileVersion/ExternalFile/Api/1/0</a> Api
<b>Explanation:</b>	Description of the version of the API

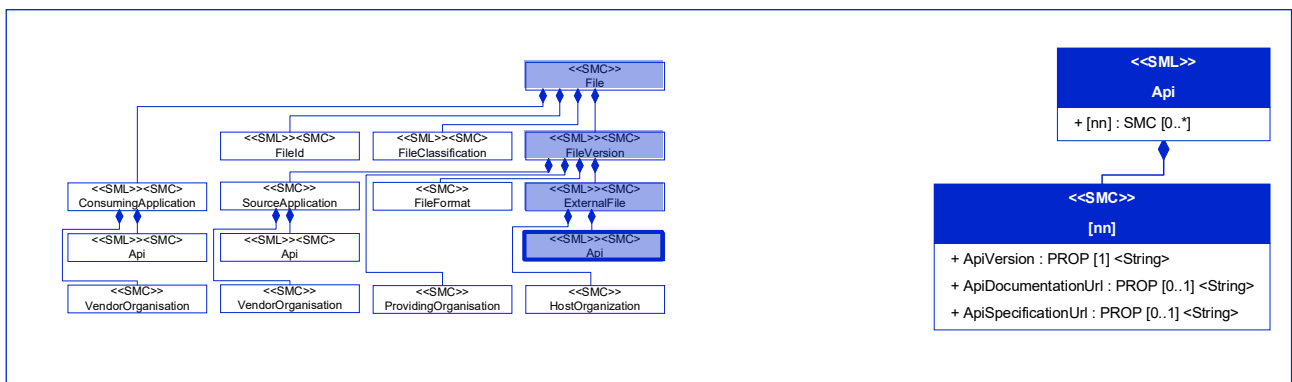

Figure 33: [Prop] ApiDocumentationUrl

Table 27: [Prop] ApiDocumentationUrl

<b>idShort:</b>	ApiDocumentationUrl
<b>Class:</b>	Property [Prop] [String]
<b>semanticId:</b>	[IRI] <a href="https://admin-shell.io/idta/Models3D/Model3D/File/FileVersion/ExternalFile/Api/ApiDocumentationUrl/1/0">https://admin-shell.io/idta/Models3D/Model3D/File/FileVersion/ExternalFile/Api/ApiDocumentationUrl/1/0</a>
<b>Parent:</b>	[IRI] <a href="https://admin-shell.io/idta/Models3D/Model3D/File/FileVersion/ExternalFile/Api/1/0">https://admin-shell.io/idta/Models3D/Model3D/File/FileVersion/ExternalFile/Api/1/0</a> Api
<b>Explanation:</b>	Link to the specification of the API.

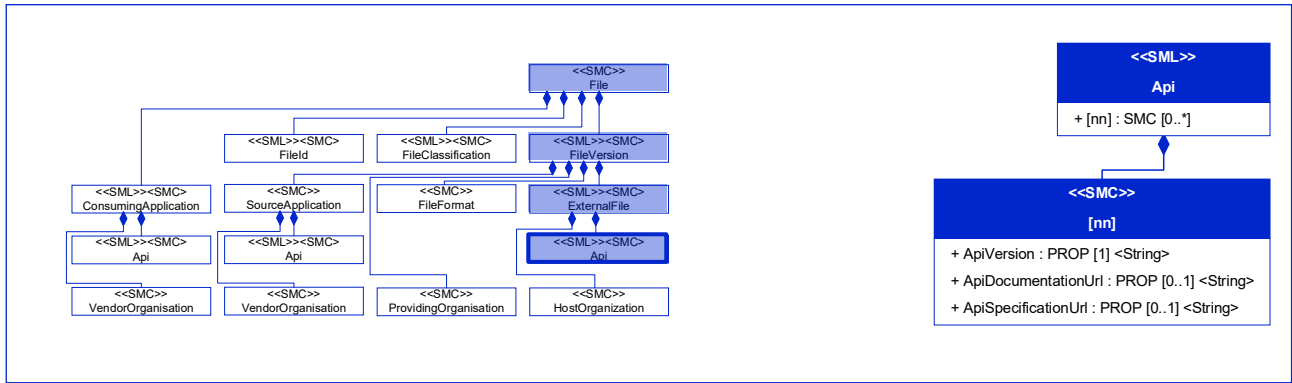

Figure 34: [Prop] ApiSpecificationUrl

Table 28: [Prop] ApiSpecificationUrl

<b>idShort:</b>	ApiSpecificationUrl
<b>Class:</b>	Property [Prop] [String]
<b>semanticId:</b>	[IRI] <a href="https://admin-shell.io/idta/Models3D/Model3D/File/FileVersion/ExternalFile/Api/ApiSpecificationUrl/1/0">https://admin-shell.io/idta/Models3D/Model3D/File/FileVersion/ExternalFile/Api/ApiSpecificationUrl/1/0</a> Api
<b>Parent:</b>	[IRI] <a href="https://admin-shell.io/idta/Models3D/Model3D/File/FileVersion/ExternalFile/Api/1/0">https://admin-shell.io/idta/Models3D/Model3D/File/FileVersion/ExternalFile/Api/1/0</a> Api
<b>Explanation:</b>	Link to the documentation of the API.

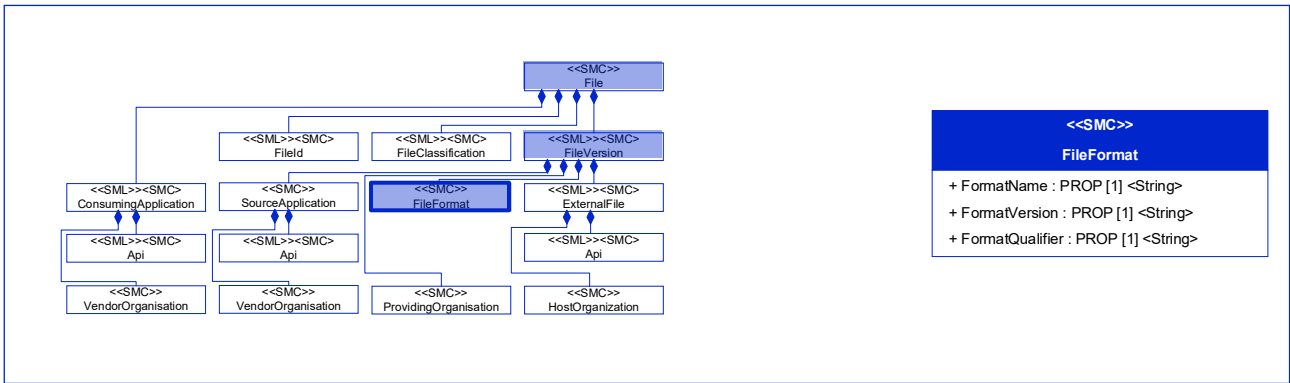

Figure 35: [SMC] FileFormat

Table 29: [SMC] FileFormat

<b>idShort:</b>	FileFormat		
<b>Class:</b>	SubmodelElementCollection [SMC]		
<b>semanticId:</b>	[IRI] <a href="https://admin-shell.io/idta/Models3D/Model3D/File/FileVersion/FileFormat/1/0">https://admin-shell.io/idta/Models3D/Model3D/File/FileVersion/FileFormat/1/0</a>		
<b>Parent:</b>	[IRI] <a href="https://admin-shell.io/idta/Models3D/Model3D/File/FileVersion/1/0">https://admin-shell.io/idta/Models3D/Model3D/File/FileVersion/1/0</a> FileVersion		
<b>Explanation:</b>	Contains information about the file format.		
<b>[SME type]</b>	<b>semanticId = [idType]value</b>	<b>[valueType]</b>	<b>card.</b>
<b>idShort</b>	<b>Description@en</b>	<b>example</b>	
[Prop] FormatName	[IRI] <a href="https://admin-shell.io/idta/Models3D/Model3D/File/FileVersion/FileFormat/FormatName/1/0">https://admin-shell.io/idta/Models3D/Model3D/File/FileVersion/FileFormat/FormatName/1/0</a> Name of the file format.	[String] STEP	1
[Prop] FormatVersion	[IRI] <a href="https://admin-shell.io/idta/Models3D/Model3D/File/FileVersion/FileFormat/FileVersion/1/0">https://admin-shell.io/idta/Models3D/Model3D/File/FileVersion/FileFormat/FileVersion/1/0</a> Version of the file format.	[String] AP242	1
[Prop] FormatQualifier	[IRI] <a href="https://admin-shell.io/idta/Models3D/Model3D/File/FileVersion/FileFormat/FormatQualifier/1/0">https://admin-shell.io/idta/Models3D/Model3D/File/FileVersion/FileFormat/FormatQualifier/1/0</a> Unique qualifier of the file format.	[String] STEP-2.03	1

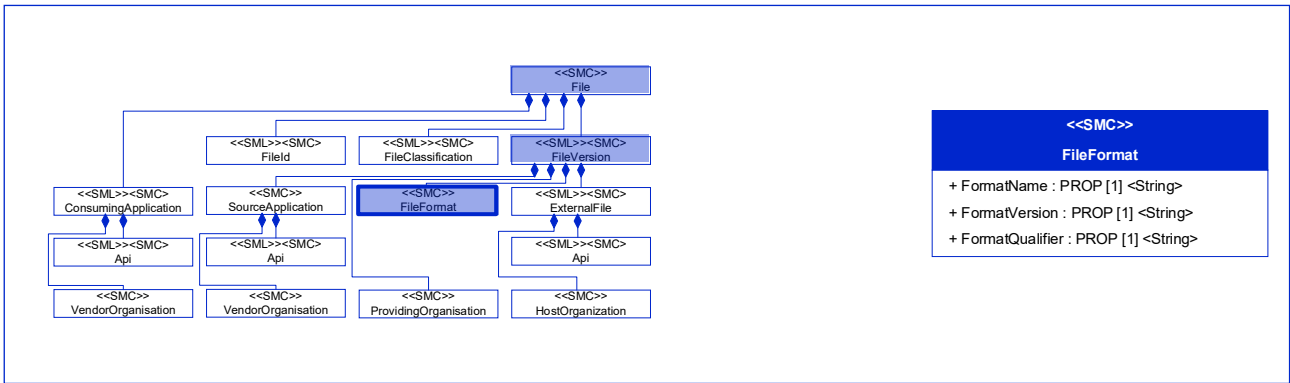

Figure 36: [Prop] FormatName

Table 30: [Prop] FormatName

<b>idShort:</b>	FormatName
<b>Class:</b>	Property [Prop] [String]
<b>semanticId:</b>	[IRI] <a href="https://admin-shell.io/idta/Models3D/Model3D/File/FileVersion/FileFormat/FormatName/1/0">https://admin-shell.io/idta/Models3D/Model3D/File/FileVersion/FileFormat/FormatName/1/0</a>
<b>Parent:</b>	[IRI] <a href="https://admin-shell.io/idta/Models3D/Model3D/File/FileVersion/FileFormat/1/0">https://admin-shell.io/idta/Models3D/Model3D/File/FileVersion/FileFormat/1/0</a> FileFormat
<b>Explanation:</b>	Name of the file format.

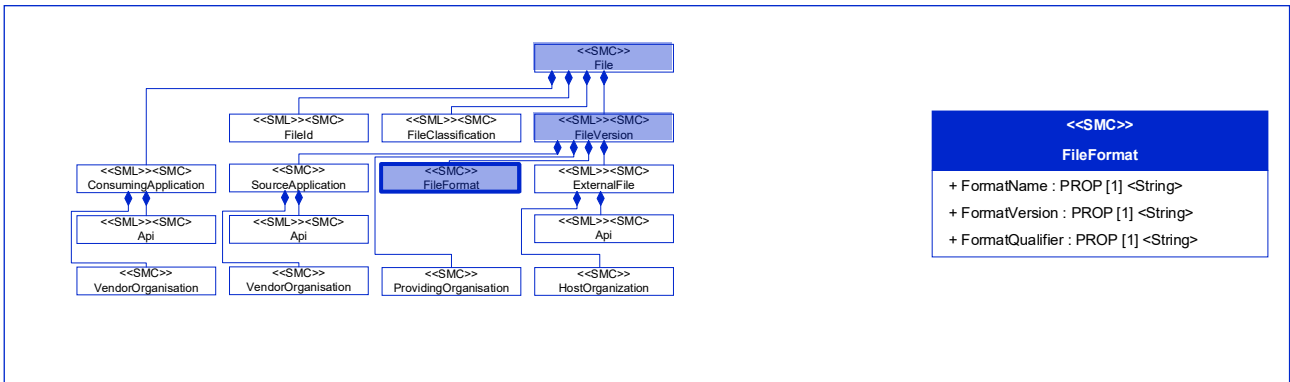

Figure 37: [Prop] FormatVersion

Table 31: [Prop] FormatVersion

<b>idShort:</b>	FormatVersion
<b>Class:</b>	Property [Prop] [String]
<b>semanticId:</b>	[IRI] <a href="https://admin-shell.io/idta/Models3D/Model3D/File/FileVersion/FileFormat/FormatVersion/1/0">https://admin-shell.io/idta/Models3D/Model3D/File/FileVersion/FileFormat/FormatVersion/1/0</a>
<b>Parent:</b>	[IRI] <a href="https://admin-shell.io/idta/Models3D/Model3D/File/FileVersion/FileFormat/1/0">https://admin-shell.io/idta/Models3D/Model3D/File/FileVersion/FileFormat/1/0</a> FileFormat
<b>Explanation:</b>	Version of the file format.

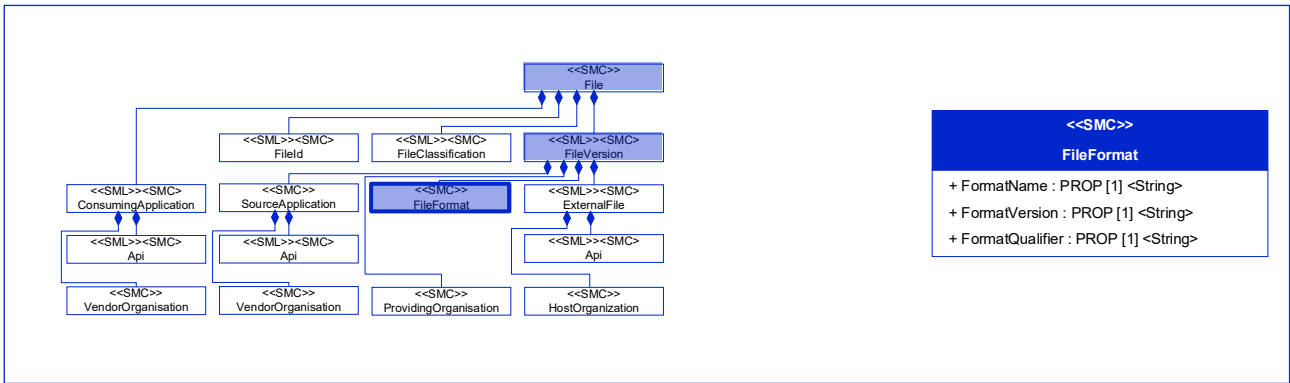

Figure 38: [Prop] FormatQualifier

Table 32: [Prop] FormatQualifier

<b>idShort:</b>	FormatQualifier
<b>Class:</b>	Property [Prop] [String]
<b>semanticId:</b>	[IRI] <a href="https://admin-shell.io/idta/Models3D/Model3D/File/FileVersion/FileFormat/FormatQualifier/1/0">https://admin-shell.io/idta/Models3D/Model3D/File/FileVersion/FileFormat/FormatQualifier/1/0</a>
<b>Parent:</b>	[IRI] <a href="https://admin-shell.io/idta/Models3D/Model3D/File/FileVersion/FileFormat/1/0">https://admin-shell.io/idta/Models3D/Model3D/File/FileVersion/FileFormat/1/0</a> FileFormat
<b>Explanation:</b>	Qualifier of the file format.

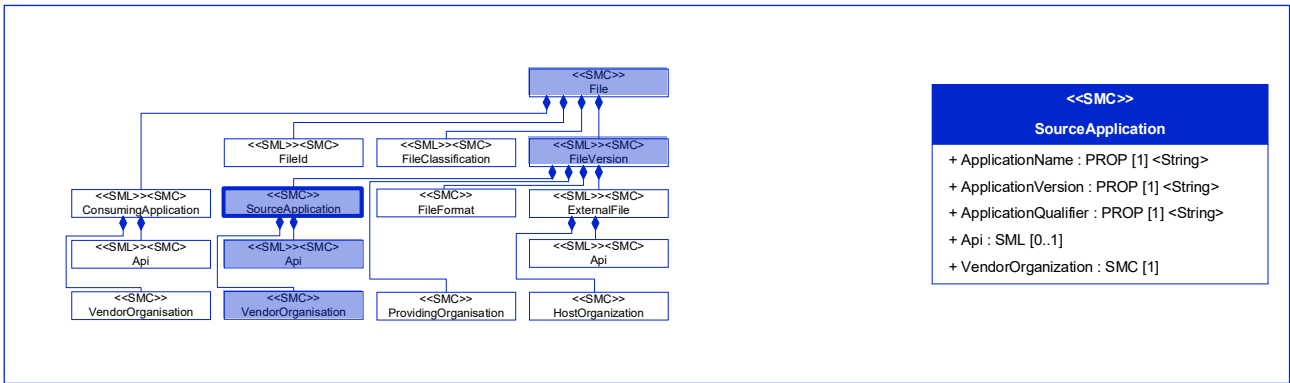

Figure 39: [SMC] SourceApplication

Table 33: [SMC] SourceApplication

<b>idShort:</b>	SourceApplication		
<b>Class:</b>	SubmodelElementCollection [SMC]		
<b>semanticId:</b>	[IRI] <a href="https://admin-shell.io/idta/Models3D/Model3D/File/FileVersion/SourceApplication/1/0">https://admin-shell.io/idta/Models3D/Model3D/File/FileVersion/SourceApplication/1/0</a>		
<b>Parent:</b>	[IRI] <a href="https://admin-shell.io/idta/Models3D/Model3D/File/FileVersion/1/0">https://admin-shell.io/idta/Models3D/Model3D/File/FileVersion/1/0</a> FileVersion		
<b>Explanation:</b>	Information about the source application the 3D model originated from.		
<b>[SME type]</b>	<b>semanticId = [idType]value</b>	<b>[valueType]</b>	<b>card.</b>
<b>idShort</b>	<b>Description@en</b>	<b>example</b>	
[Prop]	[IRI] <a href="https://admin-shell.io/idta/Models3D/Model3D/File/FileVersion/SourceApplication/ApplicationName/1/0">https://admin-shell.io/idta/Models3D/Model3D/File/FileVersion/SourceApplication/ApplicationName/1/0</a> Name of the application.	[String] STEP	1
[Prop]	[IRI] <a href="https://admin-shell.io/idta/Models3D/Model3D/File/FileVersion/SourceApplication/ApplicationVersion/1/0">https://admin-shell.io/idta/Models3D/Model3D/File/FileVersion/SourceApplication/ApplicationVersion/1/0</a> Version of the application.	[String] AP242	1
[Prop]	[IRI] <a href="https://admin-shell.io/idta/Models3D/Model3D/File/FileVersion/SourceApplication/ApplicationQualifier/1/0">https://admin-shell.io/idta/Models3D/Model3D/File/FileVersion/SourceApplication/ApplicationQualifier/1/0</a> Unique qualifier of the application.	[String] STEP-2.03	1
[SML][SMC]	[IRI] <a href="https://admin-shell.io/idta/Models3D/Model3D/File/FileVersion/SourceApplication/Api/1/0">https://admin-shell.io/idta/Models3D/Model3D/File/FileVersion/SourceApplication/Api/1/0</a> List of information about how the application programming interfaces (APIs) of the source application is defined.	[n/a]	0..1
[SMC]	[IRI] <a href="https://admin-shell.io/idta/Models3D/Model3D/File/FileVersion/SourceApplication/VendorOrganization/1/0">https://admin-shell.io/idta/Models3D/Model3D/File/FileVersion/SourceApplication/VendorOrganization/1/0</a> Information about the tool vendor organization.	[n/a]	1

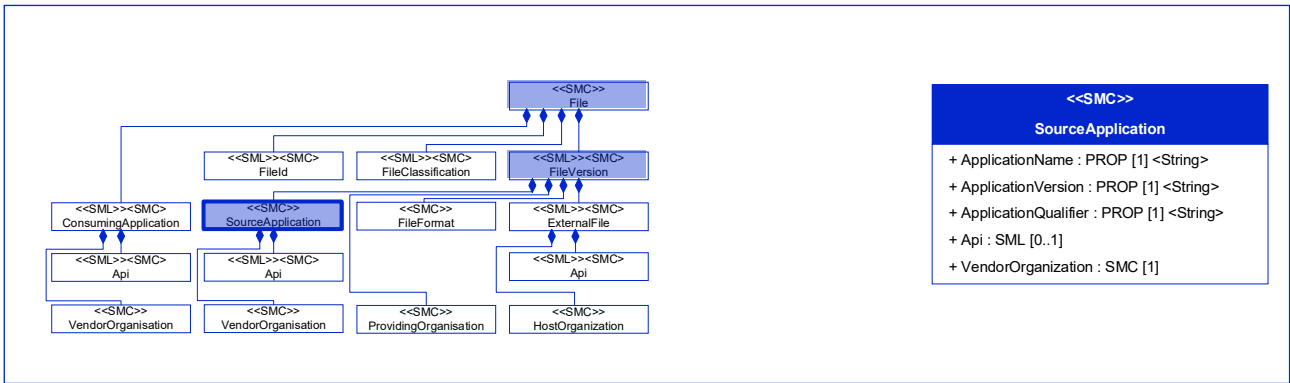

Figure 40: [Prop] ApplicationName

Table 34: [Prop] ApplicationName

<b>idShort:</b>	ApplicationName
<b>Class:</b>	Property [Prop] [String]
<b>semanticId:</b>	[IRI] <a href="https://admin-shell.io/idta/Models3D/Model3D/File/FileVersion/SourceApplication/ApplicationName/1/0">https://admin-shell.io/idta/Models3D/Model3D/File/FileVersion/SourceApplication/ApplicationName/1/0</a>
<b>Parent:</b>	[IRI] <a href="https://admin-shell.io/idta/Models3D/Model3D/File/FileVersion/SourceApplication/1/0">https://admin-shell.io/idta/Models3D/Model3D/File/FileVersion/SourceApplication/1/0</a> SourceApplication
<b>Explanation:</b>	Name of the application.

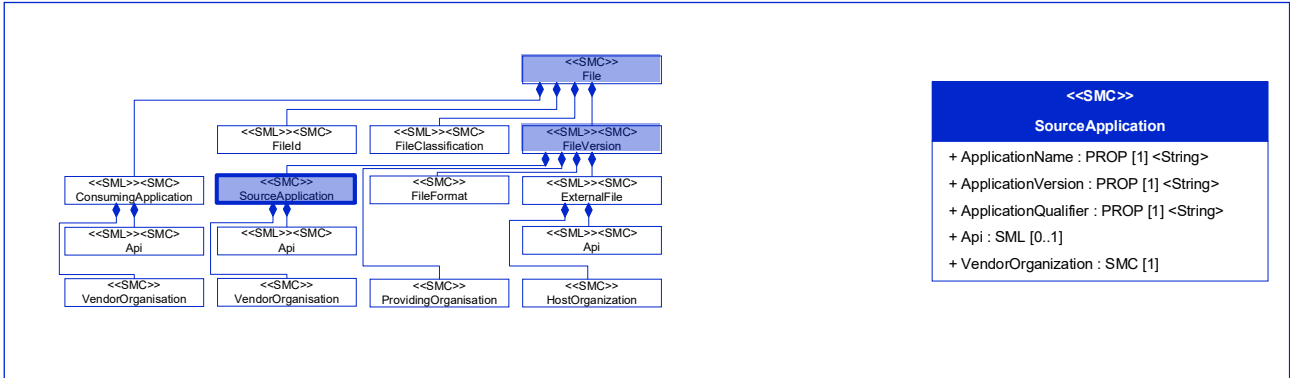

Figure 41: [Prop] ApplicationVersion

Table 35: [Prop] ApplicationVersion

<b>idShort:</b>	ApplicationVersion
<b>Class:</b>	Property [Prop] [String]
<b>semanticId:</b>	[IRI] <a href="https://admin-shell.io/idta/Models3D/Model3D/File/FileVersion/SourceApplication/ApplicationVersion/1/0">https://admin-shell.io/idta/Models3D/Model3D/File/FileVersion/SourceApplication/ApplicationVersion/1/0</a>
<b>Parent:</b>	[IRI] <a href="https://admin-shell.io/idta/Models3D/Model3D/File/FileVersion/SourceApplication/1/0">https://admin-shell.io/idta/Models3D/Model3D/File/FileVersion/SourceApplication/1/0</a> SourceApplication
<b>Explanation:</b>	Version of the application.

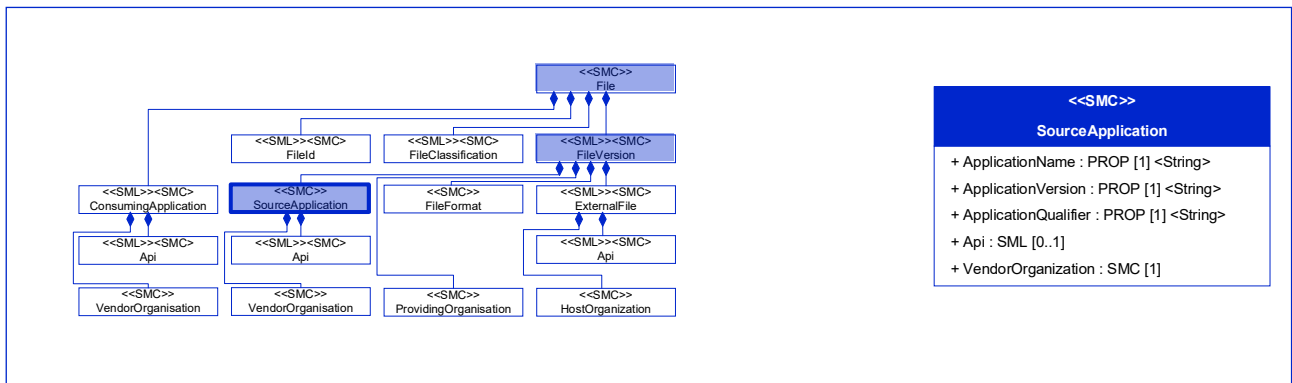

Figure 42: [Prop] ApplicationQualifier

Table 36: [Prop] ApplicationQualifier

<b>idShort:</b>	ApplicationQualifier
<b>Class:</b>	Property [Prop] [String]
<b>semanticId:</b>	[IRI] <a href="https://admin-shell.io/idta/Models3D/Model3D/File/FileVersion/SourceApplication/ApplicationQualifier/1/0">https://admin-shell.io/idta/Models3D/Model3D/File/FileVersion/SourceApplication/ApplicationQualifier/1/0</a>
<b>Parent:</b>	[IRI] <a href="https://admin-shell.io/idta/Models3D/Model3D/File/FileVersion/SourceApplication/1/0">https://admin-shell.io/idta/Models3D/Model3D/File/FileVersion/SourceApplication/1/0</a> SourceApplication
<b>Explanation:</b>	Unique qualifier of the application.

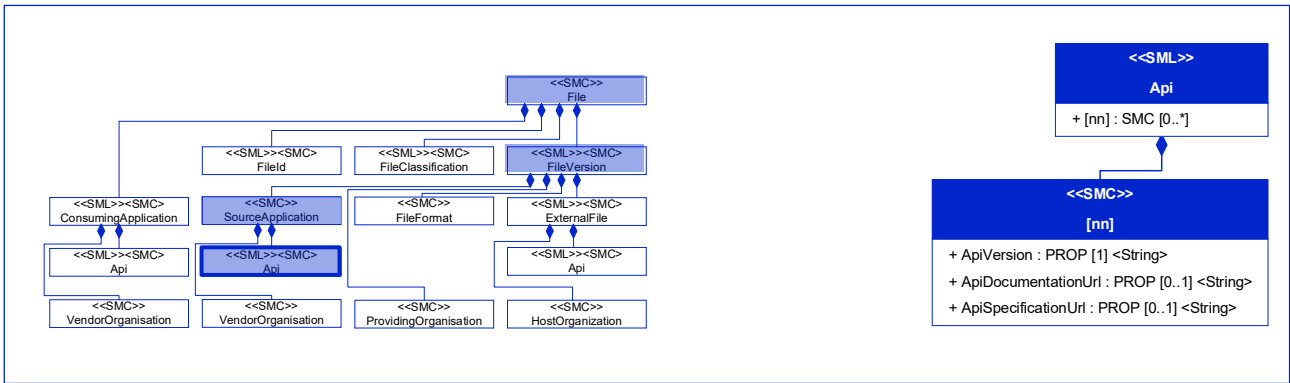

Figure 43: [SML][SMC] Api

Table 37: [SML][SMC] Api

<b>idShort:</b>	Api		
<b>Class:</b>	SubmodelElementList [SML] that contains SubmodelElementCollections [SMC]		
<b>semanticId:</b>	[IRI] <a href="https://admin-shell.io/idta/Models3D/Model3D/File/FileVersion/SourceApplication/Api/1/0">https://admin-shell.io/idta/Models3D/Model3D/File/FileVersion/SourceApplication/Api/1/0</a>		
<b>Parent:</b>	[IRI] <a href="https://admin-shell.io/idta/Models3D/Model3D/File/FileVersion/SourceApplication/1/0">https://admin-shell.io/idta/Models3D/Model3D/File/FileVersion/SourceApplication/1/0</a> SourceApplication		
<b>Explanation:</b>	List of information about how the application programming interfaces (APIs) of the source application is defined.		
<b>[SME type]</b>	<b>semanticId = [idType]value</b>	<b>[valueType]</b>	<b>card.</b>
<b>idShort</b>	<b>Description@en</b>	<b>example</b>	
[Prop] ApiVersion	[IRI] <a href="https://admin-shell.io/idta/Models3D/Model3D/File/FileVersion/SourceApplication/Api/ApiVersion/1/0">https://admin-shell.io/idta/Models3D/Model3D/File/FileVersion/SourceApplication/Api/ApiVersion/1/0</a> Description of the version of the API	[String] OpenAPI Specification – Version 3.0.1	1
[Prop] ApiDocumentationUrl	[IRI] <a href="https://admin-shell.io/idta/Models3D/Model3D/File/FileVersion/SourceApplication/Api/ApiDocumentationUrl/1/0">https://admin-shell.io/idta/Models3D/Model3D/File/FileVersion/SourceApplication/Api/ApiDocumentationUrl/1/0</a> Link to the documentation of the API.	[String] <a href="https://learn.openapis.org/">https://learn.openapis.org/</a>	0..1
[Prop] ApiSpecificationUrl	[IRI] <a href="https://admin-shell.io/idta/Models3D/Model3D/File/FileVersion/SourceApplication/Api/ApiSpecificationUrl/1/0">https://admin-shell.io/idta/Models3D/Model3D/File/FileVersion/SourceApplication/Api/ApiSpecificationUrl/1/0</a> Link to the specification of the API.	[String] <a href="https://github.com/OAI/OpenAPI-Specification/blob/main/versions/3.0.1.md">https://github.com/OAI/OpenAPI-Specification/blob/main/versions/3.0.1.md</a>	0..1

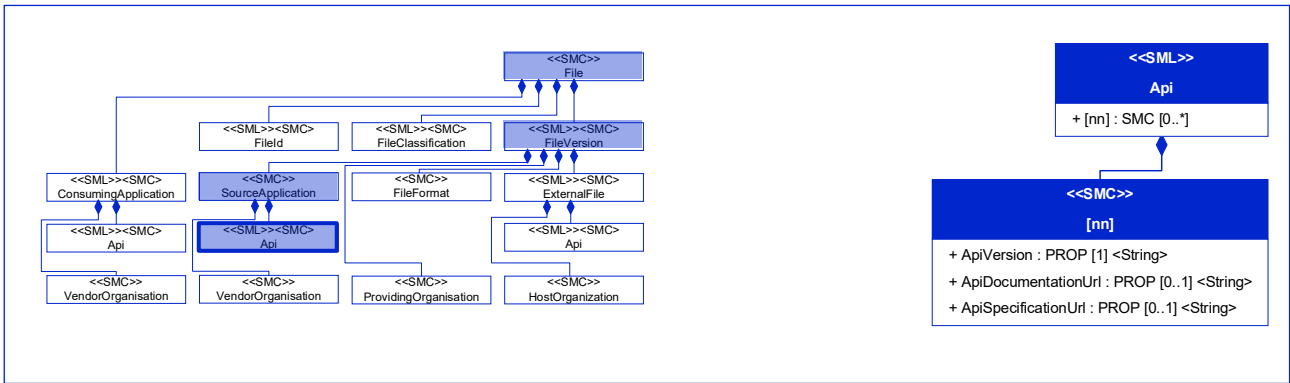

Figure 44: [Prop] ApiVersion

Table 38: [Prop] ApiVersion

<b>idShort:</b>	ApiVersion
<b>Class:</b>	Property [Prop] [String]
<b>semanticId:</b>	[IRI] <a href="https://admin-shell.io/idta/Models3D/Model3D/File/FileVersion/SourceApplication/Api/ApiVersion/1/0">https://admin-shell.io/idta/Models3D/Model3D/File/FileVersion/SourceApplication/Api/ApiVersion/1/0</a>
<b>Parent:</b>	[IRI] <a href="https://admin-shell.io/idta/Models3D/Model3D/File/FileVersion/SourceApplication/Api/1/0">https://admin-shell.io/idta/Models3D/Model3D/File/FileVersion/SourceApplication/Api/1/0</a> Api
<b>Explanation:</b>	Description of the version of the API

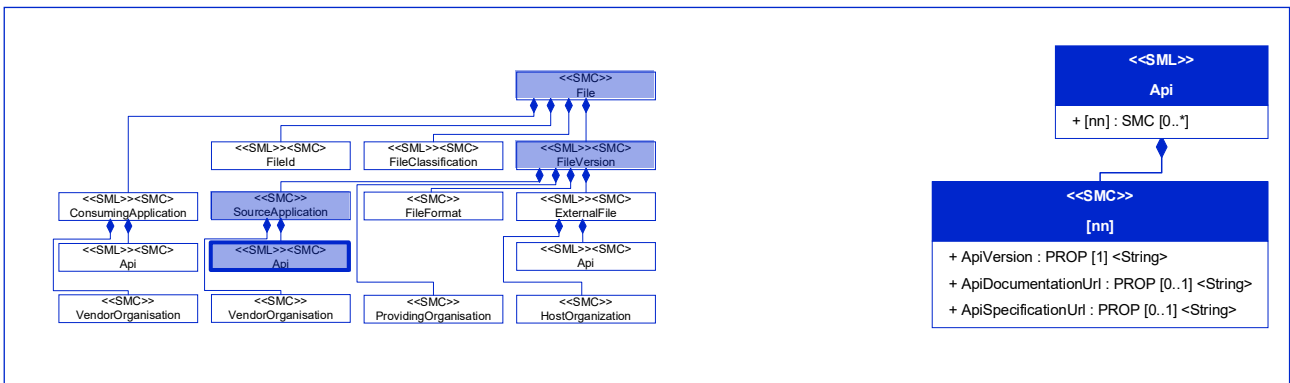

Figure 45: [Prop] ApiDocumentationUrl

Table 39: [Prop] ApiDocumentationUrl

<b>idShort:</b>	ApiDocumentationUrl
<b>Class:</b>	Property [Prop] [String]
<b>semanticId:</b>	[IRI] <a href="https://admin-shell.io/idta/Models3D/Model3D/File/FileVersion/SourceApplication/Api/ApiDocumentationUrl/1/0">https://admin-shell.io/idta/Models3D/Model3D/File/FileVersion/SourceApplication/Api/ApiDocumentationUrl/1/0</a>
<b>Parent:</b>	[IRI] <a href="https://admin-shell.io/idta/Models3D/Model3D/File/FileVersion/SourceApplication/Api/1/0">https://admin-shell.io/idta/Models3D/Model3D/File/FileVersion/SourceApplication/Api/1/0</a> Api
<b>Explanation:</b>	Link to the specification of the API.

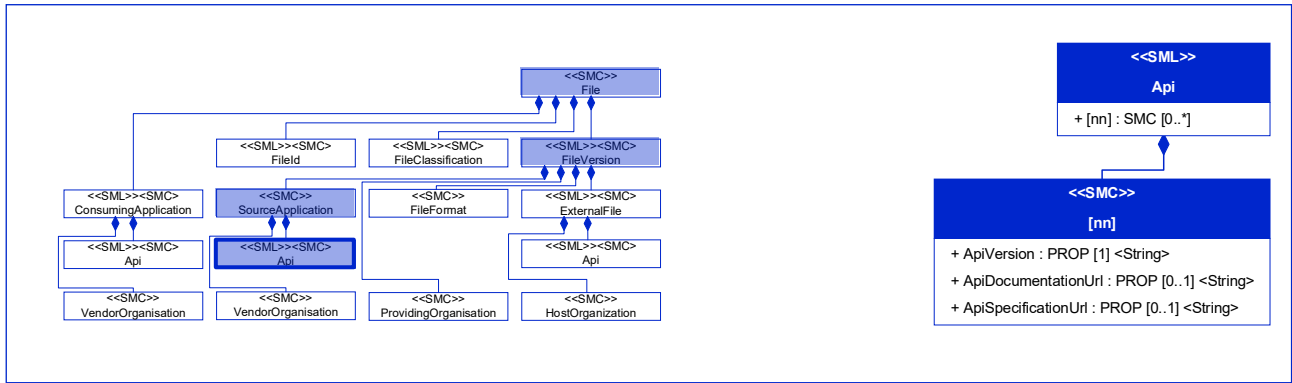

Figure 46: [Prop] ApiSpecificationUrl

Table 40: [Prop] ApiSpecificationUrl

<b>idShort:</b>	ApiSpecificationUrl
<b>Class:</b>	Property [Prop] [String]
<b>semanticId:</b>	[IRI] <a href="https://admin-shell.io/idta/Models3D/Model3D/File/FileVersion/SourceApplication/Api/ApiSpecificationUrl/1/0">https://admin-shell.io/idta/Models3D/Model3D/File/FileVersion/SourceApplication/Api/ApiSpecificationUrl/1/0</a>
<b>Parent:</b>	[IRI] <a href="https://admin-shell.io/idta/Models3D/Model3D/File/FileVersion/SourceApplication/Api/1/0">https://admin-shell.io/idta/Models3D/Model3D/File/FileVersion/SourceApplication/Api/1/0</a> Api
<b>Explanation:</b>	Link to the documentation of the API.

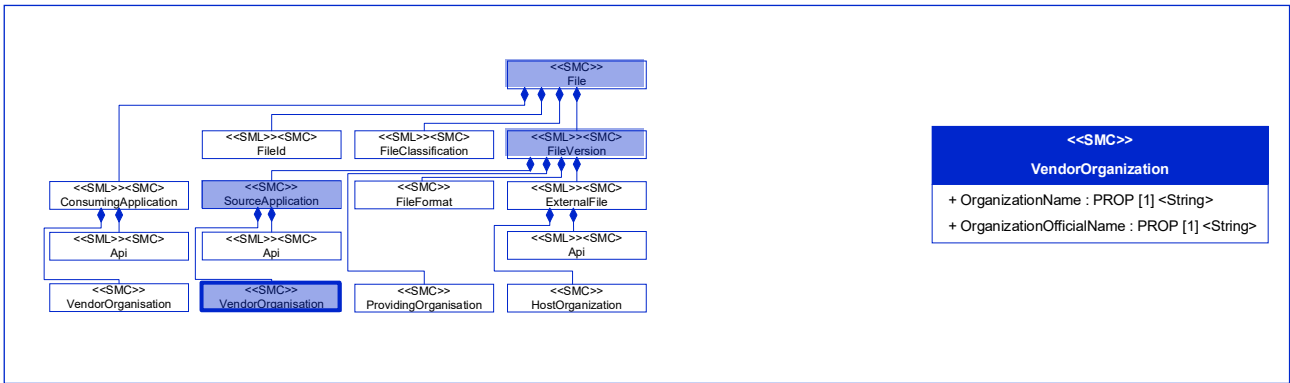

Figure 47: [SMC] VendorOrganization

Table 41: [SMC] VendorOrganization

<b>idShort:</b>	VendorOrganization		
<b>Class:</b>	SubmodelElementCollection [SMC]		
<b>semanticId:</b>	[IRI] <a href="https://admin-shell.io/idta/Models3D/Model3D/File/FileVersion/SourceApplication/VendorOrganization/1/0">https://admin-shell.io/idta/Models3D/Model3D/File/FileVersion/SourceApplication/VendorOrganization/1/0</a>		
<b>Parent:</b>	[IRI] <a href="https://admin-shell.io/idta/Models3D/Model3D/File/FileVersion/SourceApplication/1/0">https://admin-shell.io/idta/Models3D/Model3D/File/FileVersion/SourceApplication/1/0</a> SourceApplication		
<b>Explanation:</b>	Information about the tool vendor organization		
<b>[SME type]</b>	<b>semanticId = [idType]value</b>	<b>[valueType]</b>	<b>card.</b>
<b>idShort</b>	<b>Description@en</b>	<b>example</b>	
[Prop]	[IRI] <a href="https://admin-shell.io/idta/Models3D/Model3D/File/FileVersion/SourceApplication/VendorOrganization/OrganizationName/1/0">https://admin-shell.io/idta/Models3D/Model3D/File/FileVersion/SourceApplication/VendorOrganization/OrganizationName/1/0</a> Short name of the tool vendor organization.	[String] IDTA	1
[Prop]	[IRI] <a href="https://admin-shell.io/idta/Models3D/Model3D/File/FileVersion/SourceApplication/VendorOrganization/OrganizationOfficialName/1/0">https://admin-shell.io/idta/Models3D/Model3D/File/FileVersion/SourceApplication/VendorOrganization/OrganizationOfficialName/1/0</a> Official name of the tool vendor organization.	[String] Industrial Digital Twin Association e. V.	1

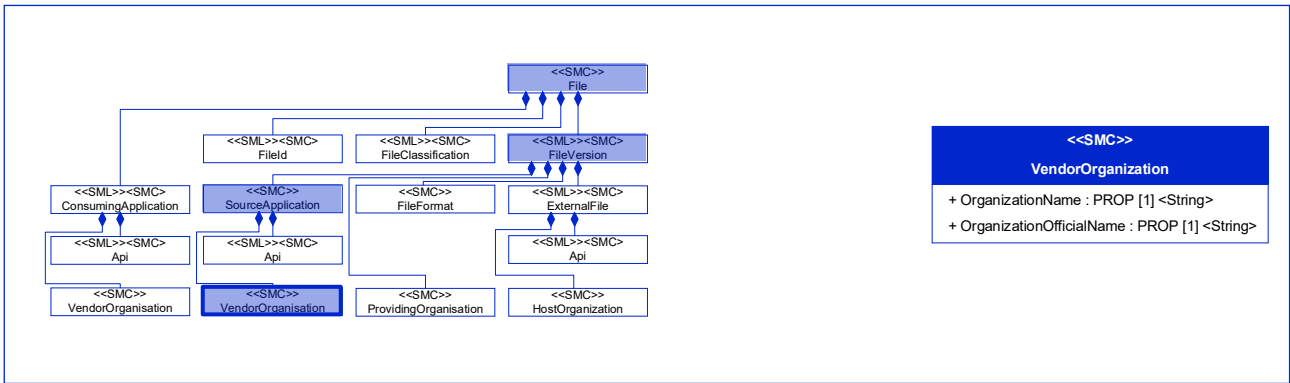

Figure 48: [Prop] OrganizationName

Table 42: [Prop] OrganizationName

<b>idShort:</b>	OrganizationName
<b>Class:</b>	Property [Prop] [String]
<b>semanticId:</b>	[IRI] <a href="https://admin-shell.io/idta/Models3D/Model3D/File/FileVersion/SourceApplication/ApplicationQualifier/VendorOrganization/OrganizationName/1/0">https://admin-shell.io/idta/Models3D/Model3D/File/FileVersion/SourceApplication/ApplicationQualifier/VendorOrganization/OrganizationName/1/0</a>
<b>Parent:</b>	[IRI] <a href="https://admin-shell.io/idta/Models3D/Model3D/File/FileVersion/SourceApplication/VendorOrganization/1/0">https://admin-shell.io/idta/Models3D/Model3D/File/FileVersion/SourceApplication/VendorOrganization/1/0</a> VendorOrganization
<b>Explanation:</b>	Short name of the tool vendor organization.

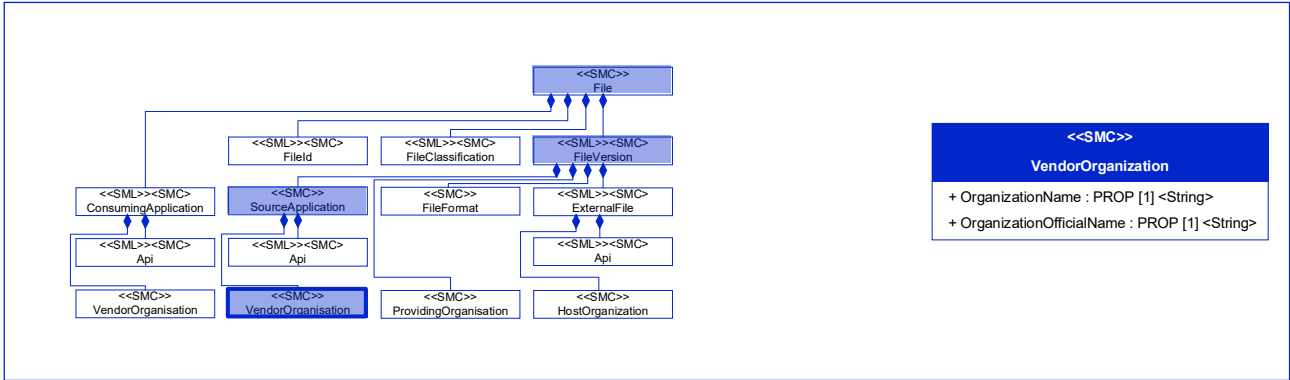

Figure 49: [Prop] OrganizationOfficialName

Table 43: [Prop] OrganizationOfficialName

<b>idShort:</b>	OrganizationOfficialName
<b>Class:</b>	Property [Prop] [String]
<b>semanticId:</b>	[IRI] <a href="https://admin-shell.io/idta/Models3D/Model3D/File/FileVersion/SourceApplication/ApplicationQualifier/VendorOrganization/OrganizationOfficialName/1/0">https://admin-shell.io/idta/Models3D/Model3D/File/FileVersion/SourceApplication/ApplicationQualifier/VendorOrganization/OrganizationOfficialName/1/0</a>
<b>Parent:</b>	[IRI] <a href="https://admin-shell.io/idta/Models3D/Model3D/File/FileVersion/SourceApplication/VendorOrganization/1/0">https://admin-shell.io/idta/Models3D/Model3D/File/FileVersion/SourceApplication/VendorOrganization/1/0</a> VendorOrganization
<b>Explanation:</b>	Official name of the tool vendor organization.

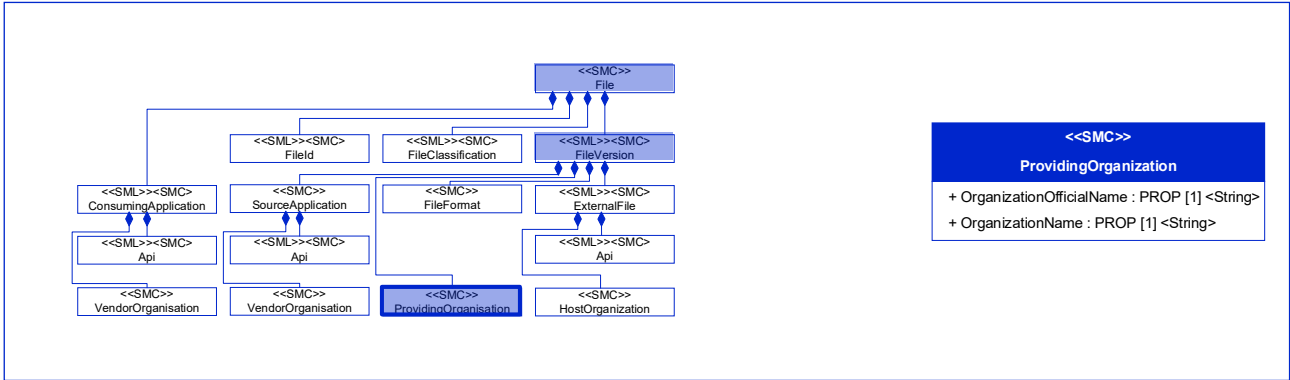

Figure 50: [SMC] ProvidingOrganization

Table 44: [SMC] ProvidingOrganization

<b>idShort:</b>	ProvidingOrganization		
<b>Class:</b>	SubmodelElementCollection [SMC]		
<b>semanticId:</b>	[IRI] <a href="https://admin-shell.io/idta/Models3D/Model3D/File/FileVersion/ProvidingOrganization/1/0">https://admin-shell.io/idta/Models3D/Model3D/File/FileVersion/ProvidingOrganization/1/0</a>		
<b>Parent:</b>	[IRI] <a href="https://admin-shell.io/idta/Models3D/Model3D/File/FileVersion/1/0">https://admin-shell.io/idta/Models3D/Model3D/File/FileVersion/1/0</a> FileVersion		
<b>Explanation:</b>	Information about the model providing organization.		
<b>[SME type]</b>	<b>semanticId = [idType]value</b>	<b>[valueType]</b>	<b>card.</b>
<b>idShort</b>	<b>Description@en</b>	<b>example</b>	
[Prop] OrganizationName	[IRI] <a href="https://admin-shell.io/idta/Models3D/Model3D/File/FileVersion/ProvidingOrganization/OrganizationName/1/0">https://admin-shell.io/idta/Models3D/Model3D/File/FileVersion/ProvidingOrganization/OrganizationName/1/0</a> Short name of the model providing organization.	[String] IDTA	1
[Prop] OrganizationOfficialName	[IRI] <a href="https://admin-shell.io/idta/Models3D/Model3D/File/FileVersion/ProvidingOrganization/OrganizationOfficialName/1/0">https://admin-shell.io/idta/Models3D/Model3D/File/FileVersion/ProvidingOrganization/OrganizationOfficialName/1/0</a> Official name of the model providing organization.	[String] Industrial Digital Twin Association e. V.	1

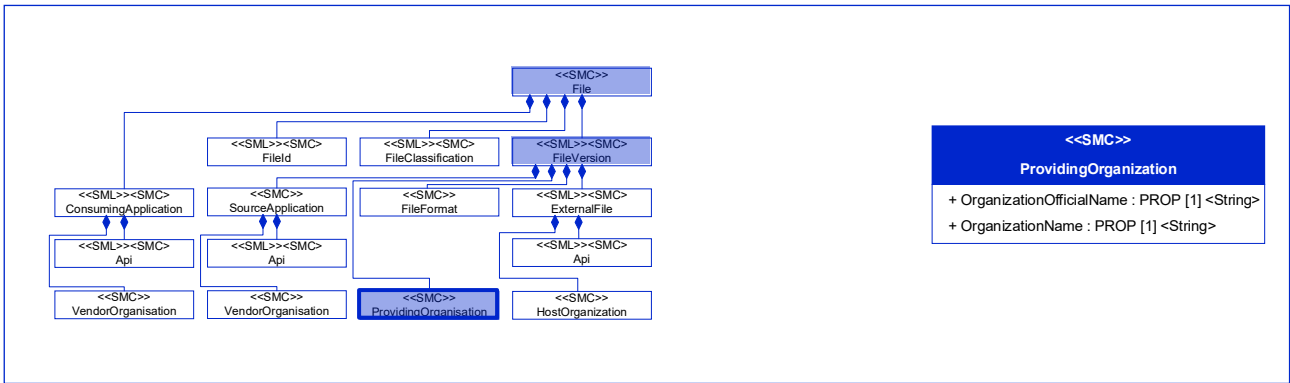

Figure 51: [Prop] OrganizationName

Table 45: [Prop] OrganizationName

<b>idShort:</b>	OrganizationName
<b>Class:</b>	Property [Prop] [String]
<b>semanticId:</b>	[IRI] <a href="https://admin-shell.io/idta/Models3D/Model3D/File/FileVersion/ProvidingOrganization/OrganizationName/1/0">https://admin-shell.io/idta/Models3D/Model3D/File/FileVersion/ProvidingOrganization/OrganizationName/1/0</a>
<b>Parent:</b>	[IRI] <a href="https://admin-shell.io/idta/Models3D/Model3D/File/FileVersion/ProvidingOrganization/1/0">https://admin-shell.io/idta/Models3D/Model3D/File/FileVersion/ProvidingOrganization/1/0</a> FileVersion
<b>Explanation:</b>	Short name of the model providing organization.

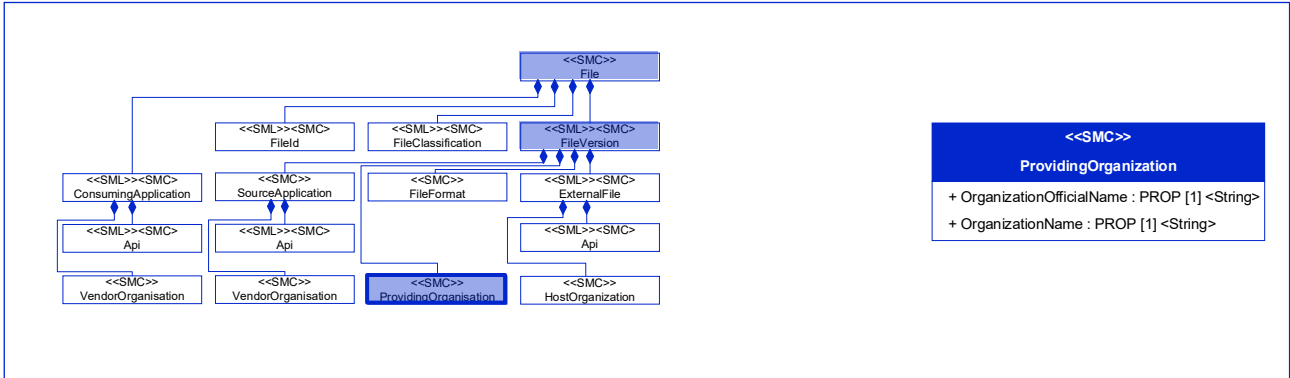

Figure 52: [Prop] OrganizationOfficialName

Table 46: [Prop] OrganizationOfficialName

<b>idShort:</b>	OrganizationOfficialName
<b>Class:</b>	Property [Prop] [String]
<b>semanticId:</b>	[IRI] <a href="https://admin-shell.io/idta/Models3D/Model3D/File/FileVersion/ProvidingOrganization/OrganizationOfficialName/1/0">https://admin-shell.io/idta/Models3D/Model3D/File/FileVersion/ProvidingOrganization/OrganizationOfficialName/1/0</a>
<b>Parent:</b>	[IRI] <a href="https://admin-shell.io/idta/Models3D/Model3D/File/FileVersion/ProvidingOrganization/1/0">https://admin-shell.io/idta/Models3D/Model3D/File/FileVersion/ProvidingOrganization/1/0</a> FileVersion
<b>Explanation:</b>	Official name of the model providing organization.

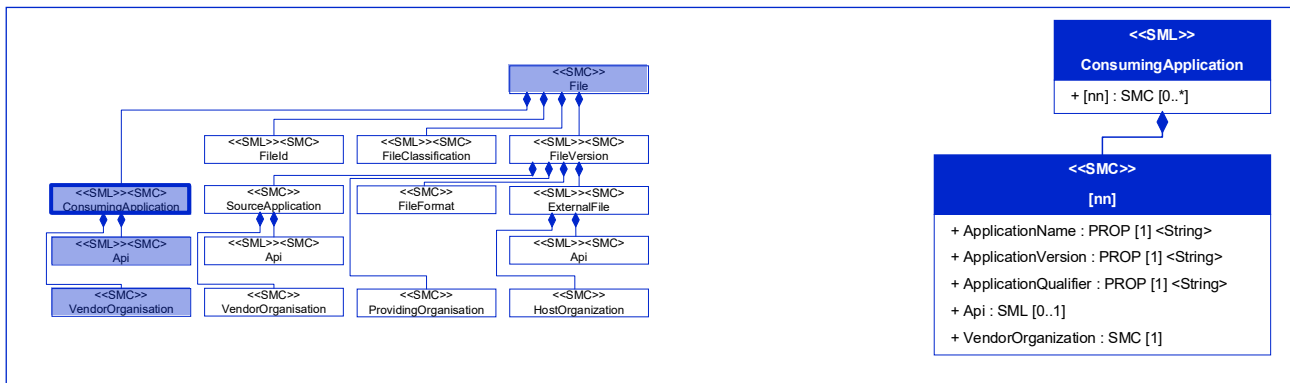

Figure 53: [SML][SMC] ConsumingApplication

Table 47: [SML][SMC] ConsumingApplication

<b>idShort:</b>	ConsumingApplication		
<b>Class:</b>	SubmodelElementList [SML] that contains SubmodelElementCollections [SMC]		
<b>semanticId:</b>	[IRI] <a href="https://admin-shell.io/idta/Models3D/Model3D/File/ConsumingApplication/1/0">https://admin-shell.io/idta/Models3D/Model3D/File/ConsumingApplication/1/0</a>		
<b>Parent:</b>	[IRI] <a href="https://admin-shell.io/idta/Models3D/Model3D/File/1/0">https://admin-shell.io/idta/Models3D/Model3D/File/1/0</a> File		
<b>Explanation:</b>	List of information about the intended consuming applications of the 3D model.		
<b>[SME type]</b>	<b>semanticId = [idType]value</b>	<b>[valueType]</b>	<b>card.</b>
<b>idShort</b>	<b>Description@en</b>	<b>example</b>	
[Prop]	[IRI] <a href="https://admin-shell.io/idta/Models3D/Model3D/File/ConsumingApplication/1/0">https://admin-shell.io/idta/Models3D/Model3D/File/ConsumingApplication/1/0</a> ApplicationName Name of the application.	[String] STEP	1
[Prop]	[IRI] <a href="https://admin-shell.io/idta/Models3D/Model3D/File/ConsumingApplication/1/0">https://admin-shell.io/idta/Models3D/Model3D/File/ConsumingApplication/1/0</a> ApplicationVersion Version of the application.	[String] AP242	1
[Prop]	[IRI] <a href="https://admin-shell.io/idta/Models3D/Model3D/File/ConsumingApplication/1/0">https://admin-shell.io/idta/Models3D/Model3D/File/ConsumingApplication/1/0</a> ApplicationQualifier Unique qualifier of the application.	[String] STEP-2.03	1
[SML][SMC]	[IRI] <a href="https://admin-shell.io/idta/Models3D/Model3D/File/ConsumingApplication/1/0">https://admin-shell.io/idta/Models3D/Model3D/File/ConsumingApplication/1/0</a> Api List of information about how the application programming interfaces (APIs) of the consuming application is defined.	[n/a]	0..1
[SMC]	[IRI] <a href="https://admin-shell.io/idta/Models3D/Model3D/File/FileConsumer/ConsumingApplication/VendorOrganization/1/0">https://admin-shell.io/idta/Models3D/Model3D/File/FileConsumer/ConsumingApplication/VendorOrganization/1/0</a> VendorOrganization Information about the tool vendor organization.	[n/a]	1

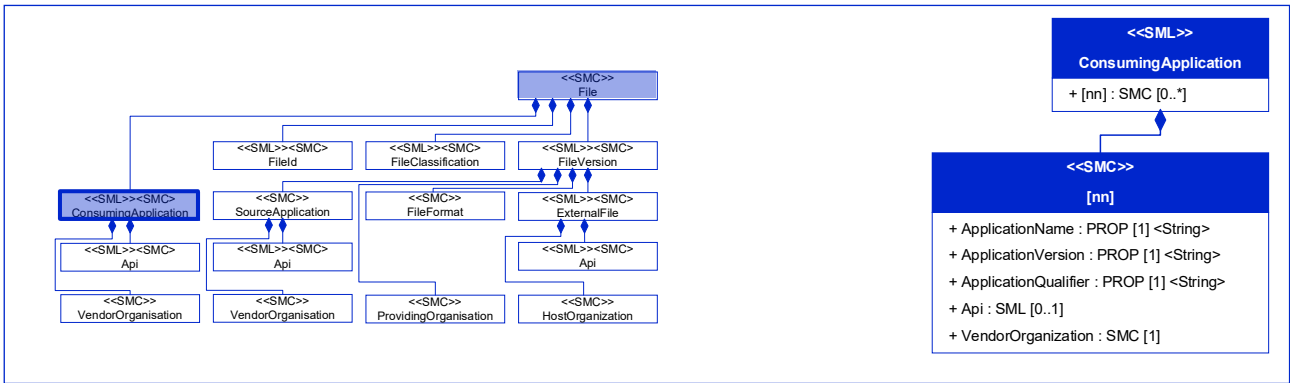

Figure 54: [Prop] ApplicationName

Table 48: [Prop] ApplicationName

<b>idShort:</b>	ApplicationName
<b>Class:</b>	Property [Prop] [String]
<b>semanticId:</b>	[IRI] <a href="https://admin-shell.io/idta/Models3D/Model3D/File/ConsumingApplication/ApplicationName/1/0">https://admin-shell.io/idta/Models3D/Model3D/File/ConsumingApplication/ApplicationName/1/0</a>
<b>Parent:</b>	[IRI] <a href="https://admin-shell.io/idta/Models3D/Model3D/File/ConsumingApplication/1/0">https://admin-shell.io/idta/Models3D/Model3D/File/ConsumingApplication/1/0</a> ConsumingApplication
<b>Explanation:</b>	Name of the application.

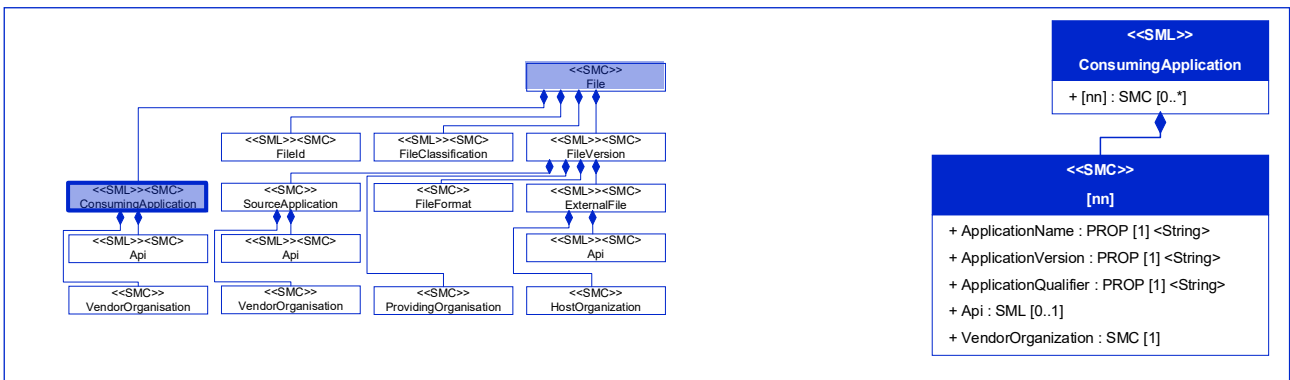

Figure 55: [Prop] ApplicationVersion

Table 49: [Prop] ApplicationVersion

<b>idShort:</b>	ApplicationVersion
<b>Class:</b>	Property [Prop] [String]
<b>semanticId:</b>	[IRI] <a href="https://admin-shell.io/idta/Models3D/Model3D/File/ConsumingApplication/ApplicationVersion/1/0">https://admin-shell.io/idta/Models3D/Model3D/File/ConsumingApplication/ApplicationVersion/1/0</a>
<b>Parent:</b>	[IRI] <a href="https://admin-shell.io/idta/Models3D/Model3D/File/ConsumingApplication/1/0">https://admin-shell.io/idta/Models3D/Model3D/File/ConsumingApplication/1/0</a> ConsumingApplication
<b>Explanation:</b>	Version of the application.

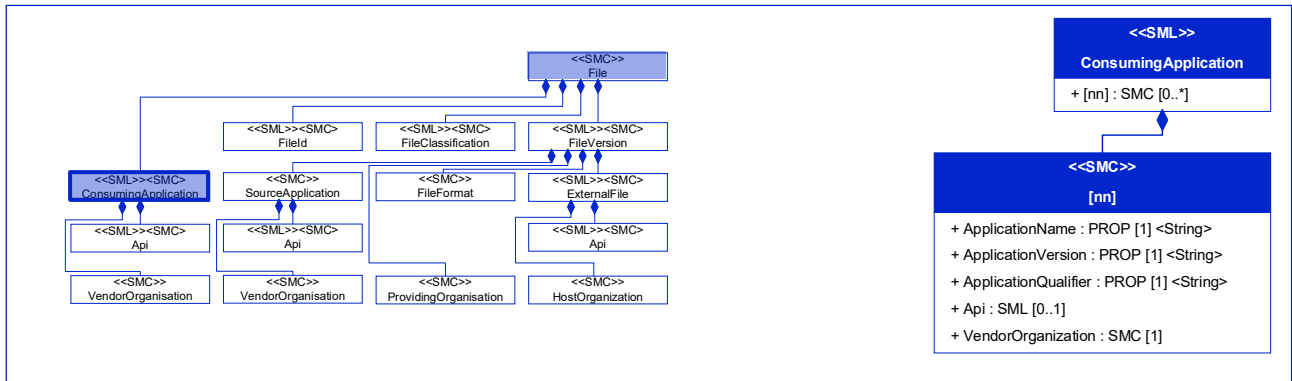

Figure 56: [Prop] ApplicationQualifier

Table 50: [Prop] ApplicationQualifier

<b>idShort:</b>	ApplicationQualifier
<b>Class:</b>	Property [Prop] [String]
<b>semanticId:</b>	[IRI] <a href="https://admin-shell.io/idta/Models3D/Model3D/File/ConsumingApplication/ApplicationQualifier/1/0">https://admin-shell.io/idta/Models3D/Model3D/File/ConsumingApplication/ApplicationQualifier/1/0</a>
<b>Parent:</b>	[IRI] <a href="https://admin-shell.io/idta/Models3D/Model3D/File/ConsumingApplication/1/0">https://admin-shell.io/idta/Models3D/Model3D/File/ConsumingApplication/1/0</a> ConsumingApplication
<b>Explanation:</b>	Unique qualifier of the application.

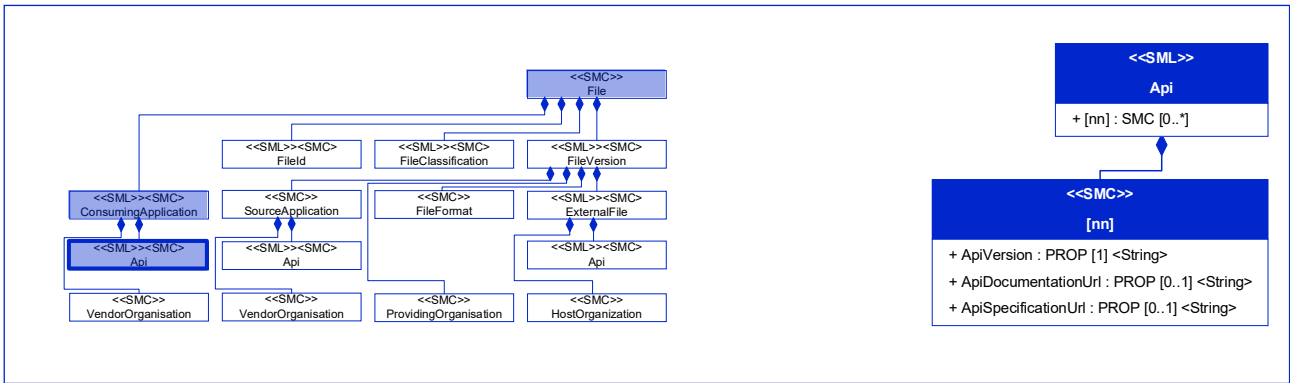

Figure 57: [SML][SMC] Api

Table 51: [SML][SMC] Api

<b>idShort:</b>	Api		
<b>Class:</b>	SubmodelElementList [SML] that contains SubmodelElementCollections [SMC]		
<b>semanticId:</b>	[IRI] <a href="https://admin-shell.io/idta/Models3D/Model3D/File/ConsumingApplication/Api/1/0">https://admin-shell.io/idta/Models3D/Model3D/File/ConsumingApplication/Api/1/0</a>		
<b>Parent:</b>	[IRI] <a href="https://admin-shell.io/idta/Models3D/Model3D/File/ConsumingApplication/1/0">https://admin-shell.io/idta/Models3D/Model3D/File/ConsumingApplication/1/0</a> ConsumingApplication		
<b>Explanation:</b>	List of information about how the application programming interfaces (APIs) of the consuming application is defined.		
<b>[SME type]</b>	<b>semanticId = [idType]value</b>	<b>[valueType]</b>	<b>card.</b>
<b>idShort</b>	<b>Description@en</b>	<b>example</b>	
[Prop] ApiVersion	[IRI] <a href="https://admin-shell.io/idta/Models3D/Model3D/File/ConsumingApplication/Api/ApiVersion/1/0">https://admin-shell.io/idta/Models3D/Model3D/File/ConsumingApplication/Api/ApiVersion/1/0</a> Description of the version of the API	[String] OpenAPI Specification – Version 3.0.1	1
[Prop] ApiDocumentationUrl	[IRI] <a href="https://admin-shell.io/idta/Models3D/Model3D/File/ConsumingApplication/Api/ApiDocumentationUrl/1/0">https://admin-shell.io/idta/Models3D/Model3D/File/ConsumingApplication/Api/ApiDocumentationUrl/1/0</a> Link to the documentation of the API.	[String] <a href="https://learn.openapis.org/">https://learn.openapis.org/</a>	0..1
[Prop] ApiSpecificationUrl	[IRI] <a href="https://admin-shell.io/idta/Models3D/Model3D/File/ConsumingApplication/Api/ApiSpecificationUrl/1/0">https://admin-shell.io/idta/Models3D/Model3D/File/ConsumingApplication/Api/ApiSpecificationUrl/1/0</a> Link to the specification of the API.	[String] <a href="https://github.com/OAI/OpenAPI-Specification/blob/main/versions/3.0.1.md">https://github.com/OAI/OpenAPI-Specification/blob/main/versions/3.0.1.md</a>	0..1

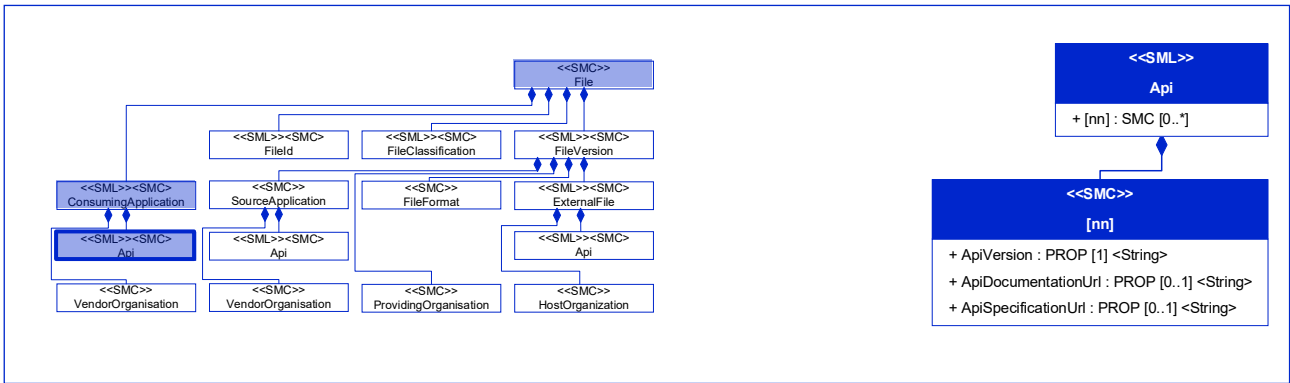

Figure 58: [Prop] ApiVersion

Table 52: [Prop] ApiVersion

<b>idShort:</b>	ApiVersion
<b>Class:</b>	Property [Prop] [String]
<b>semanticId:</b>	[IRI] <a href="https://admin-shell.io/idta/Models3D/Model3D/File/ConsumingApplication/Api/ApiVersion/1/0">https://admin-shell.io/idta/Models3D/Model3D/File/ConsumingApplication/Api/ApiVersion/1/0</a>
<b>Parent:</b>	[IRI] <a href="https://admin-shell.io/idta/Models3D/Model3D/File/ConsumingApplication/Api/1/0">https://admin-shell.io/idta/Models3D/Model3D/File/ConsumingApplication/Api/1/0</a> Api
<b>Explanation:</b>	Description of the version of the API

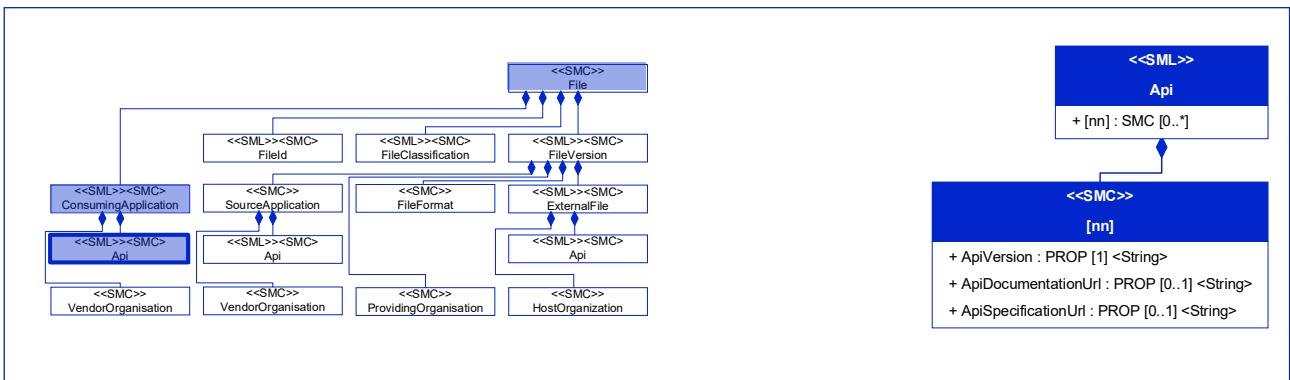

Figure 59: [Prop] ApiDocumentation

Table 53: [Prop] ApiDocumentation

<b>idShort:</b>	ApiDocumentationUrl
<b>Class:</b>	Property [Prop] [String]
<b>semanticId:</b>	[IRI] <a href="https://admin-shell.io/idta/Models3D/Model3D/File/ConsumingApplication/Api/ApiDocumentationUrl/1/0">https://admin-shell.io/idta/Models3D/Model3D/File/ConsumingApplication/Api/ApiDocumentationUrl/1/0</a>
<b>Parent:</b>	[IRI] <a href="https://admin-shell.io/idta/Models3D/Model3D/File/ConsumingApplication/Api/1/0">https://admin-shell.io/idta/Models3D/Model3D/File/ConsumingApplication/Api/1/0</a> Api
<b>Explanation:</b>	Link to the specification of the API.

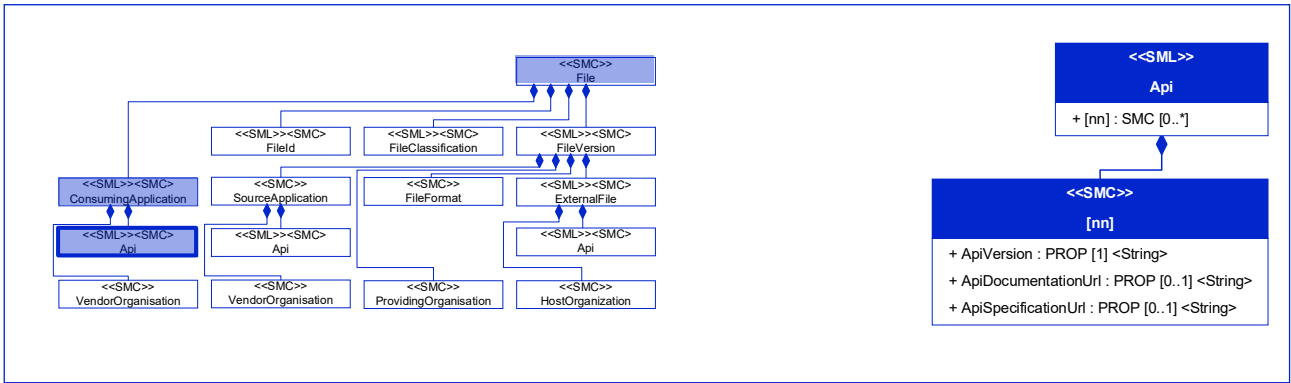

Figure 60: [Prop] ApiSpecificationUrl

Table 54: [Prop] ApiSpecificationUrl

<b>idShort:</b>	ApiSpecificationUrl
<b>Class:</b>	Property [Prop] [String]
<b>semanticId:</b>	[IRI] <a href="https://admin-shell.io/idta/Models3D/Model3D/File/ConsumingApplication/Api/ApiSpecificationUrl/1/0">https://admin-shell.io/idta/Models3D/Model3D/File/ConsumingApplication/Api/ApiSpecificationUrl/1/0</a>
<b>Parent:</b>	[IRI] <a href="https://admin-shell.io/idta/Models3D/Model3D/File/ConsumingApplication/Api/1/0">https://admin-shell.io/idta/Models3D/Model3D/File/ConsumingApplication/Api/1/0</a> Api
<b>Explanation:</b>	Link to the documentation of the API.

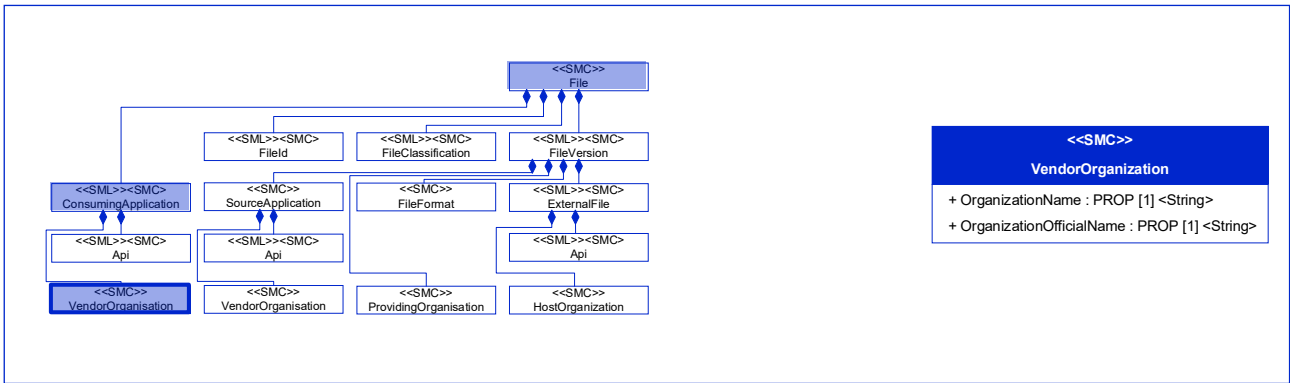

Figure 61: [SMC] VendorOrganization

Table 55: [SMC] VendorOrganization

<b>idShort:</b>	VendorOrganization		
<b>Class:</b>	SubmodelElementCollection [SMC]		
<b>semanticId:</b>	[IRI] <a href="https://admin-shell.io/idta/Models3D/Model3D/File/ConsumingApplication/VendorOrganization/1/0">https://admin-shell.io/idta/Models3D/Model3D/File/ConsumingApplication/VendorOrganization/1/0</a>		
<b>Parent:</b>	[IRI] <a href="https://admin-shell.io/idta/Models3D/Model3D/File/ConsumingApplication/1/0">https://admin-shell.io/idta/Models3D/Model3D/File/ConsumingApplication/1/0</a> ConsumingApplication		
<b>Explanation:</b>	Information about the tool vendor organization.		
<b>[SME type]</b>	<b>semanticId = [idType]value</b>	<b>[valueType]</b>	<b>card.</b>
<b>idShort</b>	<b>Description@en</b>	<b>example</b>	
[Prop]	[IRI] <a href="https://admin-shell.io/idta/Models3D/Model3D/File/ConsumingApplication/VendorOrganization/OrganizationName/1/0">https://admin-shell.io/idta/Models3D/Model3D/File/ConsumingApplication/VendorOrganization/OrganizationName/1/0</a> Short name of the tool vendor organization.	[String] IDTA	1
[Prop]	[IRI] <a href="https://admin-shell.io/idta/Models3D/Model3D/File/ConsumingApplication/VendorOrganization/OrganizationOfficialName/1/0">https://admin-shell.io/idta/Models3D/Model3D/File/ConsumingApplication/VendorOrganization/OrganizationOfficialName/1/0</a> Official name of the tool vendor organization.	[String] Industrial Digital Twin Association e. V.	1

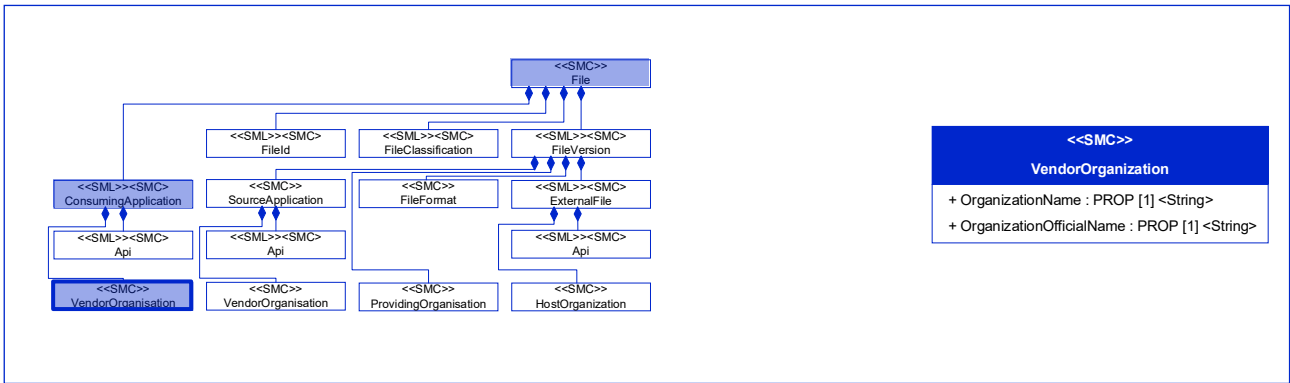

Figure 62: [Prop] OrganizationName

Table 56: [Prop] OrganizationName

<b>idShort:</b>	OrganizationName
<b>Class:</b>	Property [Prop] [String]
<b>semanticId:</b>	[IRI] <a href="https://admin-shell.io/idta/Models3D/Model3D/File/ConsumingApplication/VendorOrganization/OrganizationName/1/0">https://admin-shell.io/idta/Models3D/Model3D/File/ConsumingApplication/VendorOrganization/OrganizationName/1/0</a>
<b>Parent:</b>	[IRI] <a href="https://admin-shell.io/idta/Models3D/Model3D/File/ConsumingApplication/VendorOrganization/1/0">https://admin-shell.io/idta/Models3D/Model3D/File/ConsumingApplication/VendorOrganization/1/0</a> VendorOrganization
<b>Explanation:</b>	Short name of the tool vendor organization.

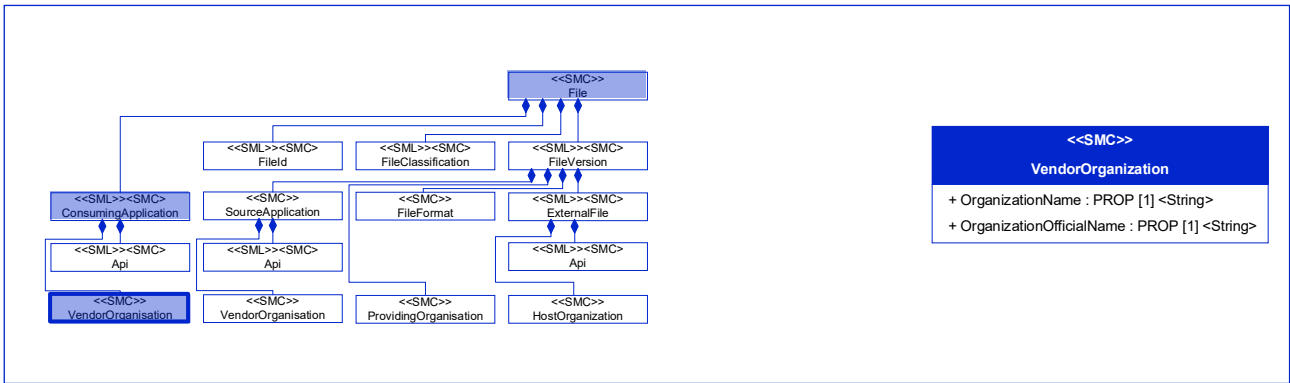

Figure 63: [Prop] OrganizationOfficialName

Table 57: [Prop] OrganizationOfficialName

<b>idShort:</b>	OrganizationOfficialName
<b>Class:</b>	Property [Prop] [String]
<b>semanticId:</b>	[IRI] <a href="https://admin-shell.io/idta/Models3D/Model3D/File/ConsumingApplication/VendorOrganization/OrganizationOfficialName/1/0">https://admin-shell.io/idta/Models3D/Model3D/File/ConsumingApplication/VendorOrganization/OrganizationOfficialName/1/0</a>
<b>Parent:</b>	[IRI] <a href="https://admin-shell.io/idta/Models3D/Model3D/File/ConsumingApplication/VendorOrganization/1/0">https://admin-shell.io/idta/Models3D/Model3D/File/ConsumingApplication/VendorOrganization/1/0</a> VendorOrganization
<b>Explanation:</b>	Official name of the tool vendor organization.

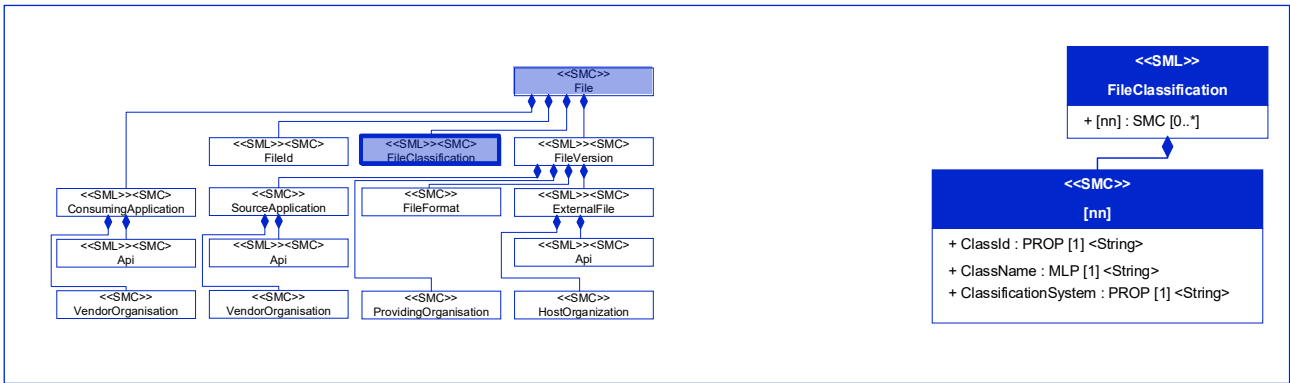

Figure 64: [SML][SMC] FileClassification

Table 58: [SML][SMC] FileClassification

<b>idShort:</b>	FileClassification		
<b>Class:</b>	SubmodelElementList [SML] that contains SubmodelElementCollections [SMC]		
<b>semanticId:</b>	[IRI] <a href="https://admin-shell.io/idta/Models3D/Model3D/File/FileClassification/1/0">https://admin-shell.io/idta/Models3D/Model3D/File/FileClassification/1/0</a>		
<b>Parent:</b>	[IRI] <a href="https://admin-shell.io/idta/Models3D/Model3D/File/1/0">https://admin-shell.io/idta/Models3D/Model3D/File/1/0</a> File		
<b>Explanation:</b>	List of information for describing the classification of the file according to ClassificationSystems.		
<b>[SME type]</b>	<b>semanticId = [idType]value</b>	<b>[valueType]</b>	<b>card.</b>
<b>idShort</b>	<b>Description@en</b>	<b>example</b>	
[Prop]	[IRI] <a href="https://admin-shell.io/idta/Models3D/Model3D/File/FileClassification/ClassId/1/0">https://admin-shell.io/idta/Models3D/Model3D/File/FileClassification/ClassId/1/0</a>  Unique ID of the document class within a ClassificationSystem.	[String] 02-02	1
[MLP]	[IRI] <a href="https://admin-shell.io/idta/Models3D/Model3D/File/FileClassification/ClassName/1/0">https://admin-shell.io/idta/Models3D/Model3D/File/FileClassification/ClassName/1/0</a>  List of language-dependent names of the selected ClassID.	[String] Drawings, plans	1
[Prop]	[IRI] <a href="https://admin-shell.io/idta/Models3D/Model3D/File/ClassificationSystem/1/0">https://admin-shell.io/idta/Models3D/Model3D/File/ClassificationSystem/1/0</a>  Identification of the classification system.	[String] VDI2770:2020	1

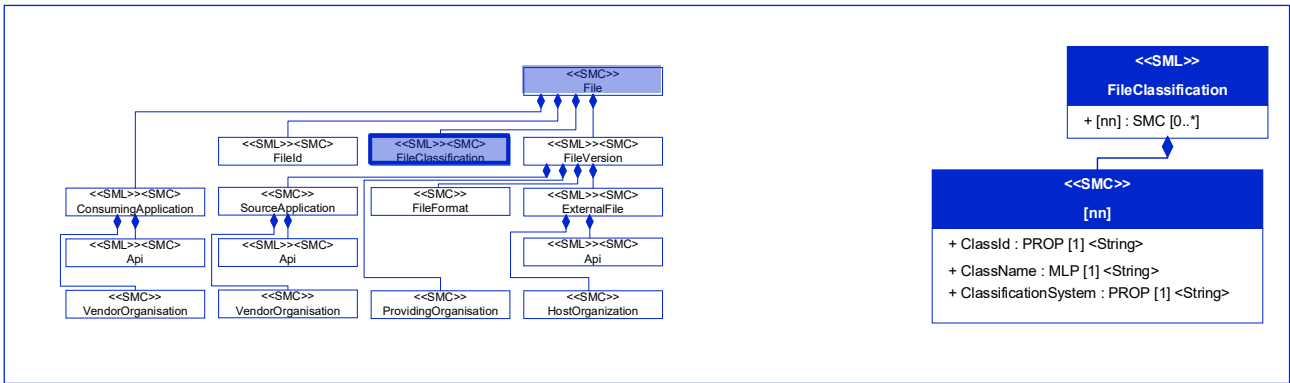

Figure 65: [Prop] ClassId

Table 59: [Prop] ClassId

<b>idShort:</b>	ClassId
<b>Class:</b>	Property [Prop] [String]
<b>semanticId:</b>	[IRI] <a href="https://admin-shell.io/idta/Models3D/Model3D/File/FileClassification/ClassId/1/0">https://admin-shell.io/idta/Models3D/Model3D/File/FileClassification/ClassId/1/0</a>
<b>Parent:</b>	[IRI] <a href="https://admin-shell.io/idta/Models3D/Model3D/File/FileClassification/1/0">https://admin-shell.io/idta/Models3D/Model3D/File/FileClassification/1/0</a> FileClassification
<b>Explanation:</b>	Unique ID of the document class within a ClassificationSystem.

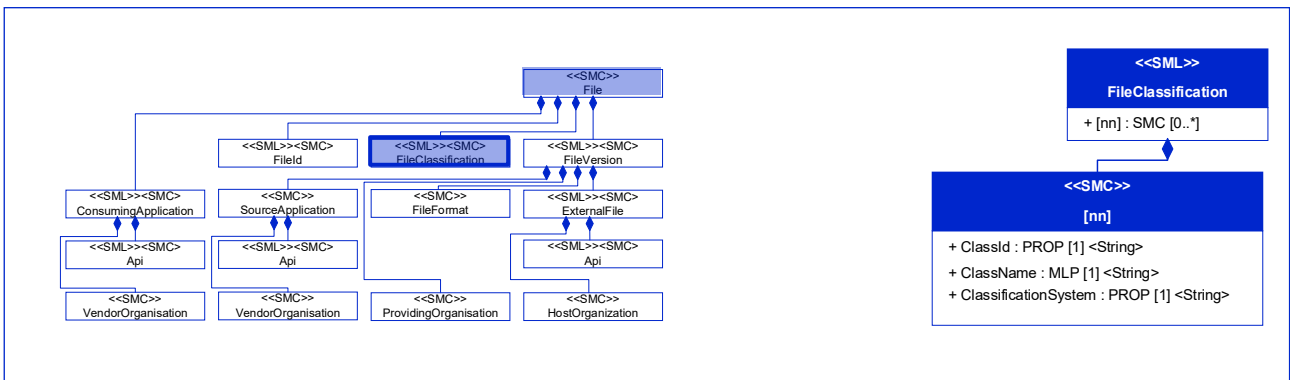

Figure 66: [MLP] ClassName

Table 60: [MLP] ClassName

<b>idShort:</b>	ClassName
<b>Class:</b>	MultiLanguageProperty [MLP] [String]
<b>semanticId:</b>	[IRI] <a href="https://admin-shell.io/idta/Models3D/Model3D/File/FileClassification/ClassName/1/0">https://admin-shell.io/idta/Models3D/Model3D/File/FileClassification/ClassName/1/0</a>
<b>Parent:</b>	[IRI] <a href="https://admin-shell.io/idta/Models3D/Model3D/File/FileClassification/1/0">https://admin-shell.io/idta/Models3D/Model3D/File/FileClassification/1/0</a> FileClassification
<b>Explanation:</b>	List of language-dependent names of the selected ClassID.

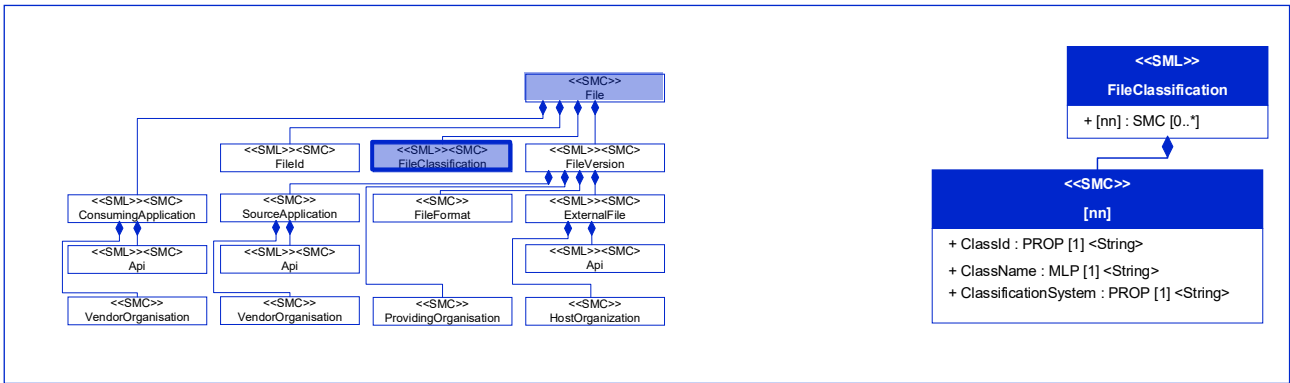

Figure 67: [Prop] ClassificationSystem

Table 61: [Prop] ClassificationSystem

<b>idShort:</b>	ClassificationSystem
<b>Class:</b>	Property [Prop] [String]
<b>semanticId:</b>	[IRI] <a href="https://admin-shell.io/idta/Models3D/Model3D/File/FileClassification/ClassificationSystem/1/0">https://admin-shell.io/idta/Models3D/Model3D/File/FileClassification/ClassificationSystem/1/0</a>
<b>Parent:</b>	[IRI] <a href="https://admin-shell.io/idta/Models3D/Model3D/File/FileClassification/1/0">https://admin-shell.io/idta/Models3D/Model3D/File/FileClassification/1/0</a> FileClassification
<b>Explanation:</b>	Identification of the classification system.

### 2.2.3 [SMC] Capability

The [SMC] Capability describes what can be done and what shouldn't be done with the model. Another point is how "trustworthy" the model is. Have elements been removed e.g. to save computational power or to protect IP? Is the geometry based on a measurement of an instance or designed? Describes the model an intermediate status in the whole process chain? Figure 68 shows the [SMC] Capability as well as the conceptual connection to the [ValueLists] and [CommonSME].

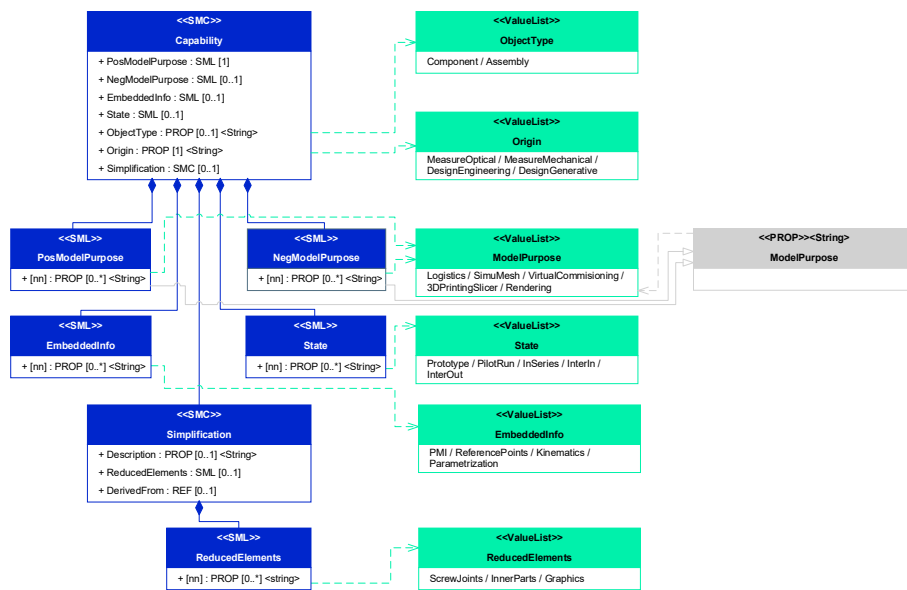

Figure 68: [SMC] Capability

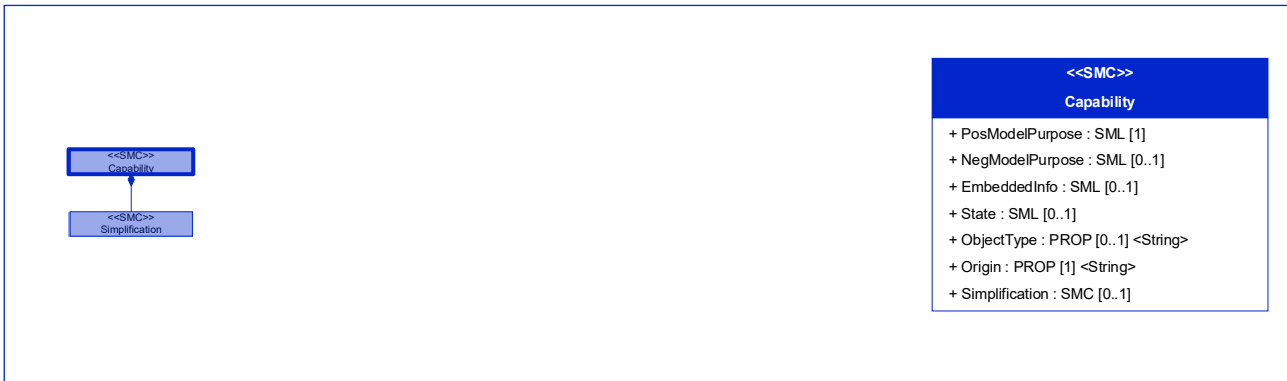

Figure 69: [SMC] Capability

Table 62: [SMC] Capability

<b>idShort:</b>	Capability		
<b>Class:</b>	SubmodelElementCollection [SMC]		
<b>semanticId:</b>	[IRI] <a href="https://admin-shell.io/idta/Models3D/Model3D/Capability/1/0">https://admin-shell.io/idta/Models3D/Model3D/Capability/1/0</a>		
<b>Parent:</b>	[IRI] <a href="https://admin-shell.io/idta/Models3D/Model3D/1/0">https://admin-shell.io/idta/Models3D/Model3D/1/0</a> Model3D		
<b>Explanation:</b>	Information about the model capability.		
<b>[SME type]</b>	<b>semanticId = [idType]value</b>	<b>[valueType]</b>	<b>card.</b>
<b>idShort</b>	<b>Description@en</b>	<b>example</b>	
[SML][Prop] PosModelPurpose	[IRI] <a href="https://admin-shell.io/idta/Models3D/Model3D/Capability/PosModelPurpose/1/0">https://admin-shell.io/idta/Models3D/Model3D/Capability/PosModelPurpose/1/0</a>  List of purposes for which the model is explicitly suitable.  Use ValueList – ModelPurpose	[String]  FDM Simulation	1
[SML][Prop] NegModelPurpose	[IRI] <a href="https://admin-shell.io/idta/Models3D/Model3D/Capability/NegModelPurpose/1/0">https://admin-shell.io/idta/Models3D/Model3D/Capability/NegModelPurpose/1/0</a>  List of purposes for which the model is explicitly not suitable.  Use ValueList – ModelPurpose	[String]  Rendering	0..1
[SML][Prop] EmbeddedInfo	[IRI] <a href="https://admin-shell.io/idta/Models3D/Model3D/Capability/EmbeddedInfo/1/0">https://admin-shell.io/idta/Models3D/Model3D/Capability/EmbeddedInfo/1/0</a>  List of further information that are embedded in the 3D model file itself.  Use ValueList – EmbeddedInfo	[String]  Reference Points	0..1
[SML][Prop] State	[IRI] <a href="https://admin-shell.io/idta/Models3D/Model3D/Capability/State/1/0">https://admin-shell.io/idta/Models3D/Model3D/Capability/State/1/0</a>  List of states or maturity in the products lifecycle which is represented by the model.  Use ValueList – State	[String]  Manufacturing in	0..1

[Prop] ObjectType	[IRI] <a href="https://admin-shell.io/idta/Models3D/Model3D/Capability/ObjectType/1/0">https://admin-shell.io/idta/Models3D/Model3D/Capability/ObjectType/1/0</a> Object type in terms of CAD structure. Use ValueList – ObjectType	[String] Assembly	0..1
[Prop] Origin	[IRI] <a href="https://admin-shell.io/idta/Models3D/Model3D/Capability/Origin/1/0">https://admin-shell.io/idta/Models3D/Model3D/Capability/Origin/1/0</a> Origin on which the model is based on. Use ValueList – Origin	[String] Modeling	1
[SMC] Simplification	[IRI] <a href="https://admin-shell.io/idta/Models3D/Model3D/Capability/Simplification/1/0">https://admin-shell.io/idta/Models3D/Model3D/Capability/Simplification/1/0</a> Information what was simplified in this [SMC] Model3D compared to a reference [SMC] Model 3D, in this case [REF] DerivedFrom.	[n/a]	0..1

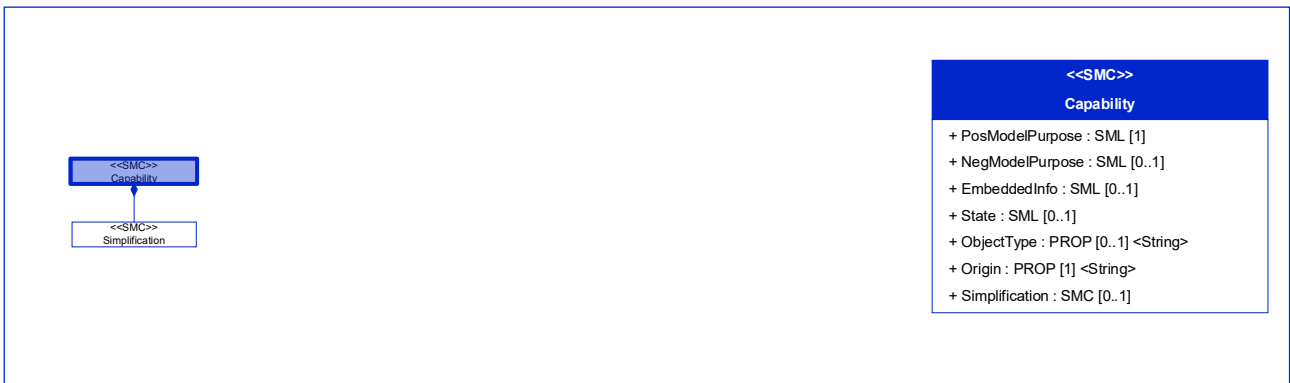

Figure 70: [SML][Prop] PosModelPurpose

Table 63: [SML][Prop] PosModelPurpose

<b>idShort:</b>	PosModelPurpose
<b>Class:</b>	SubmodelElementList [SML] of Properties [Prop] [String]
<b>semanticId:</b>	[IRI] <a href="https://admin-shell.io/idta/Models3D/Model3D/Capability/PosModelPurpose/1/0">https://admin-shell.io/idta/Models3D/Model3D/Capability/PosModelPurpose/1/0</a>
<b>Parent:</b>	[IRI] <a href="https://admin-shell.io/idta/Models3D/Model3D/Capability/1/0">https://admin-shell.io/idta/Models3D/Model3D/Capability/1/0</a> Capability
<b>Explanation:</b>	List of purposes for which the model is explicitly suitable. Use ValueList – ModelPurpose

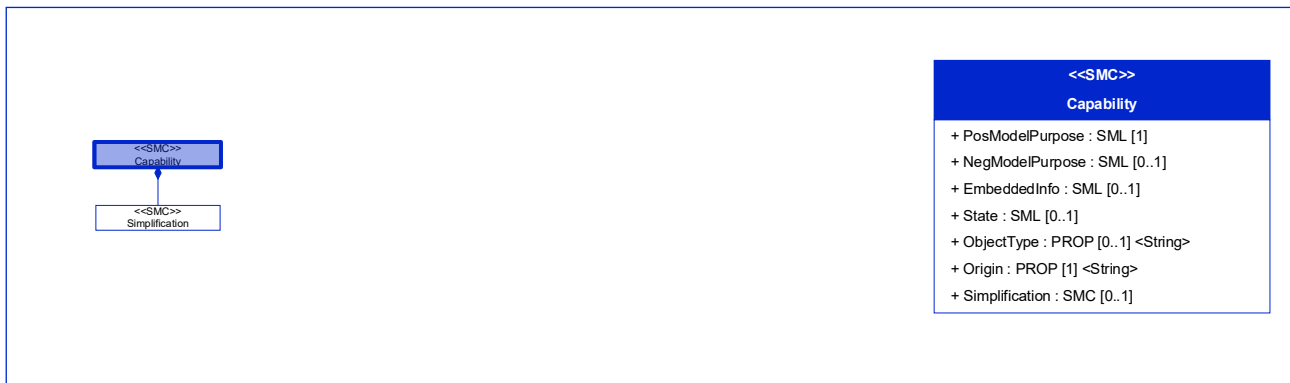

Figure 71: [SML][Prop] NegModelPurpose

Table 64: [SML][Prop] NegModelPurpose

<b>idShort:</b>	NegModelPurpose
<b>Class:</b>	SubmodelElementList [SML] of Properties [Prop] [String]
<b>semanticId:</b>	[IRI] <a href="https://admin-shell.io/idta/Models3D/Model3D/Capability/NegModelPurpose/1/0">https://admin-shell.io/idta/Models3D/Model3D/Capability/NegModelPurpose/1/0</a>
<b>Parent:</b>	[IRI] <a href="https://admin-shell.io/idta/Models3D/Model3D/Capability/1/0">https://admin-shell.io/idta/Models3D/Model3D/Capability/1/0</a> Capability
<b>Explanation:</b>	List of purposes for which the model is explicitly not suitable. Use ValueList – ModelPurpose



Figure 72: [Prop] EmbeddedInfo

Table 65: [SML][Prop] EmbeddedInfo

<b>idShort:</b>	Embedded Info
<b>Class:</b>	SubmodelElementList [SML] of Properties [Prop] [String]
<b>semanticId:</b>	[IRI] <a href="https://admin-shell.io/idta/Models3D/Model3D/Capability/EmbeddedInfo/1/0">https://admin-shell.io/idta/Models3D/Model3D/Capability/EmbeddedInfo/1/0</a>
<b>Parent:</b>	[IRI] <a href="https://admin-shell.io/idta/Models3D/Model3D/Capability/1/0">https://admin-shell.io/idta/Models3D/Model3D/Capability/1/0</a> Capability
<b>Explanation:</b>	List of further information that are embedded in the 3D model file itself. Use ValueList – EmbeddedInfo

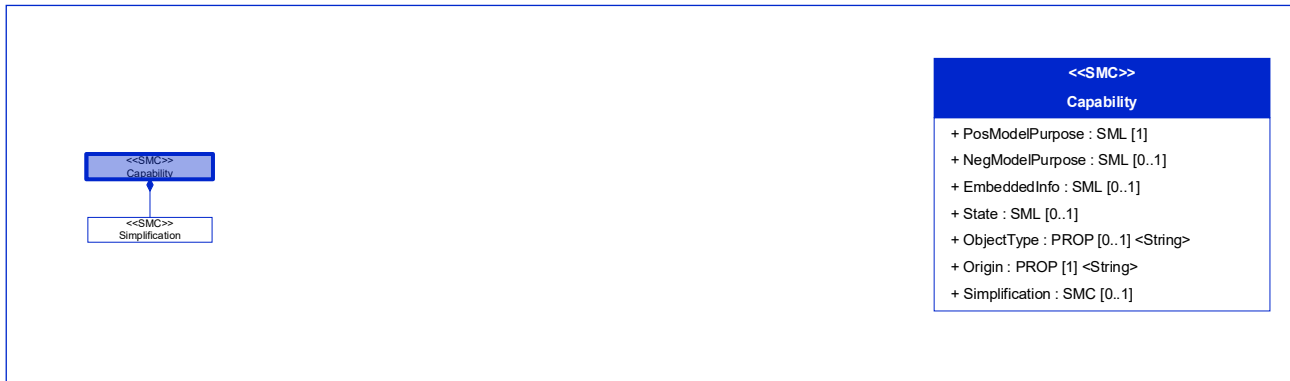

<<SMC>> Capability
+ PosModelPurpose : SML [1]
+ NegModelPurpose : SML [0..1]
+ EmbeddedInfo : SML [0..1]
+ State : SML [0..1]
+ ObjectType : PROP [0..1] <String>
+ Origin : PROP [1] <String>
+ Simplification : SMC [0..1]

Figure 73: [SML][Prop] State

Table 66: [SML][Prop] State

<b>idShort:</b>	State
<b>Class:</b>	Property [Prop] [String]
<b>semanticId:</b>	[IRI] <a href="https://admin-shell.io/idta/Models3D/Model3D/Capability/State/1/0">https://admin-shell.io/idta/Models3D/Model3D/Capability/State/1/0</a>
<b>Parent:</b>	[IRI] <a href="https://admin-shell.io/idta/Models3D/Model3D/Capability/1/0">https://admin-shell.io/idta/Models3D/Model3D/Capability/1/0</a> Capability
<b>Explanation:</b>	List of states or maturity in the products lifecycle which is represented by the model. Use ValueList – State



Figure 74: [Prop] ObjectType

Table 67: [Prop] ObjectType

<b>idShort:</b>	ObjectType
<b>Class:</b>	Property [Prop] [String]
<b>semanticId:</b>	[IRI] <a href="https://admin-shell.io/idta/Models3D/Model3D/Capability/ObjectType/1/0">https://admin-shell.io/idta/Models3D/Model3D/Capability/ObjectType/1/0</a>
<b>Parent:</b>	[IRI] <a href="https://admin-shell.io/idta/Models3D/Model3D/Capability/1/0">https://admin-shell.io/idta/Models3D/Model3D/Capability/1/0</a> Capability
<b>Explanation:</b>	Object type in terms of CAD structure. Use ValueList – ObjectType



Figure 75: [Prop] Origin

Table 68: [Prop] Origin

<b>idShort:</b>	Origin
<b>Class:</b>	Property [Prop] [String]
<b>semanticId:</b>	[IRI] <a href="https://admin-shell.io/idta/Models3D/Model3D/Capability/Origin/1/0">https://admin-shell.io/idta/Models3D/Model3D/Capability/Origin/1/0</a>
<b>Parent:</b>	[IRI] <a href="https://admin-shell.io/idta/Models3D/Model3D/Capability/1/0">https://admin-shell.io/idta/Models3D/Model3D/Capability/1/0</a> Capability
<b>Explanation:</b>	Origin on which the model is based on. Use ValueList – Origin

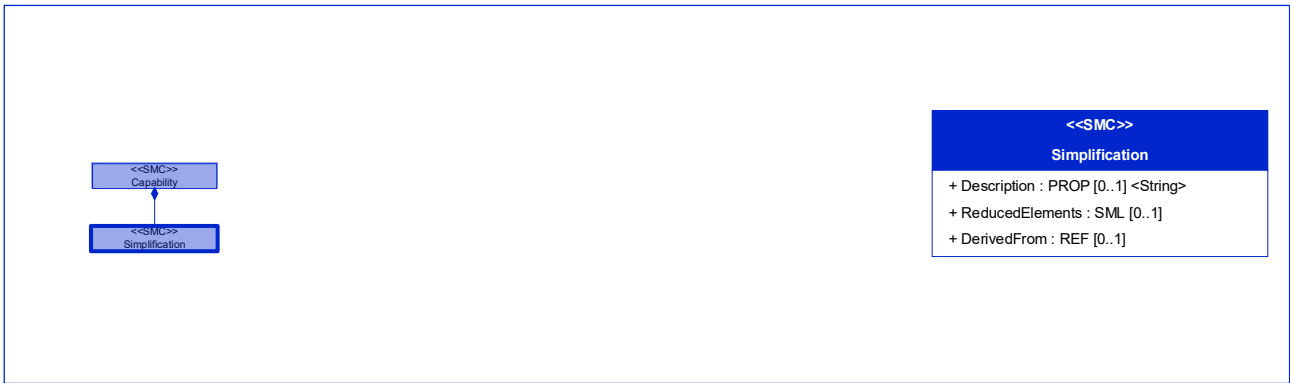

Figure 76: [SMC] Simplification

Table 69: [SMC] Simplification

<b>idShort:</b>	Simplification		
<b>Class:</b>	SubmodelElementCollection [SMC]		
<b>semanticId:</b>	[IRI] <a href="https://admin-shell.io/idta/Models3D/Model3D/Capability/Simplification/1/0">https://admin-shell.io/idta/Models3D/Model3D/Capability/Simplification/1/0</a>		
<b>Parent:</b>	[IRI] <a href="https://admin-shell.io/idta/Models3D/Model3D/Capability/1/0">https://admin-shell.io/idta/Models3D/Model3D/Capability/1/0</a> Capability		
<b>Explanation:</b>	Information what was simplified in this [SMC] Model3D compared to a reference [SMC] Model 3D, in this case [REF] DerivedFrom.		
<b>[SME type]</b>	<b>semanticId = [idType]value</b>	<b>[valueType]</b>	<b>card.</b>
<b>idShort</b>	<b>Description@en</b>	<b>example</b>	
[Prop] Description	[IRI] <a href="https://admin-shell.io/idta/Models3D/Model3D/Capability/Simplification/LevelDescription/1/0">https://admin-shell.io/idta/Models3D/Model3D/Capability/Simplification/LevelDescription/1/0</a>  Textual description of what was simplified.	[String]  In comparison to the 3D model this 3D model was derived from, all screw joints were removed.	0..1
[SML][Prop] ReducedElements	[IRI] <a href="https://admin-shell.io/idta/Models3D/Model3D/Capability/Simplification/ReducedElements/1/0">https://admin-shell.io/idta/Models3D/Model3D/Capability/Simplification/ReducedElements/1/0</a>  List of information about what elements were reduced, in comparison to the model this model was derived from.  Use ValueList – ReducedElements	[String]  Screw Joints	0..1
[Ref] DerivedFrom	[IRI] <a href="https://admin-shell.io/idta/Models3D/Model3D/Capability/Simplification/DerivedFrom/1/0">https://admin-shell.io/idta/Models3D/Model3D/Capability/Simplification/DerivedFrom/1/0</a>  Reference points to a [SMC] “Model3D” on which this [SMC] “Model3D” is based on.	[n/a]	0..1

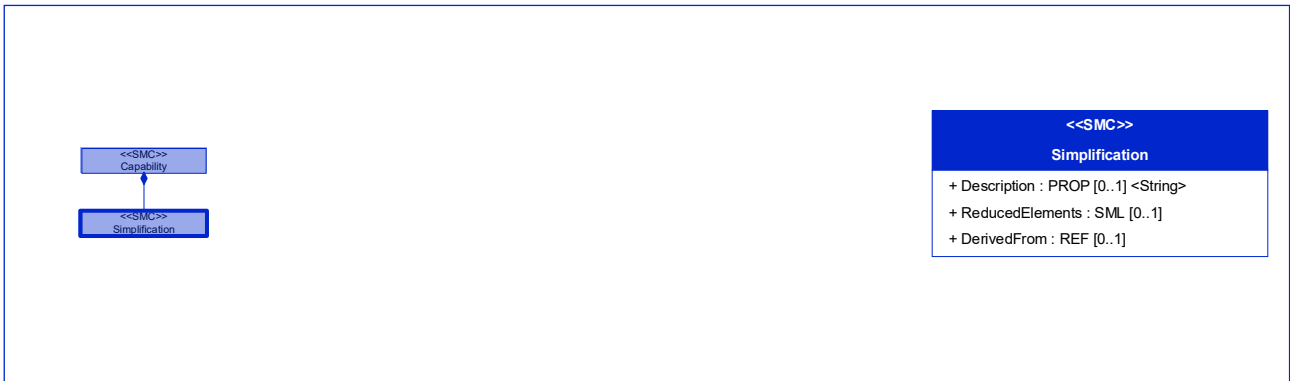

Figure 77: [Prop] Description

Table 70: [Prop] Description

<b>idShort:</b>	Description
<b>Class:</b>	Property [Prop] [String]
<b>semanticId:</b>	[IRI] <a href="https://admin-shell.io/idta/Models3D/Model3D/Capability/Simplification/Description/1/0">https://admin-shell.io/idta/Models3D/Model3D/Capability/Simplification/Description/1/0</a>
<b>Parent:</b>	[IRI] <a href="https://admin-shell.io/idta/Models3D/Model3D/Capability/Simplification/1/0">https://admin-shell.io/idta/Models3D/Model3D/Capability/Simplification/1/0</a> Simplification
<b>Explanation:</b>	Textual description of what was simplified.

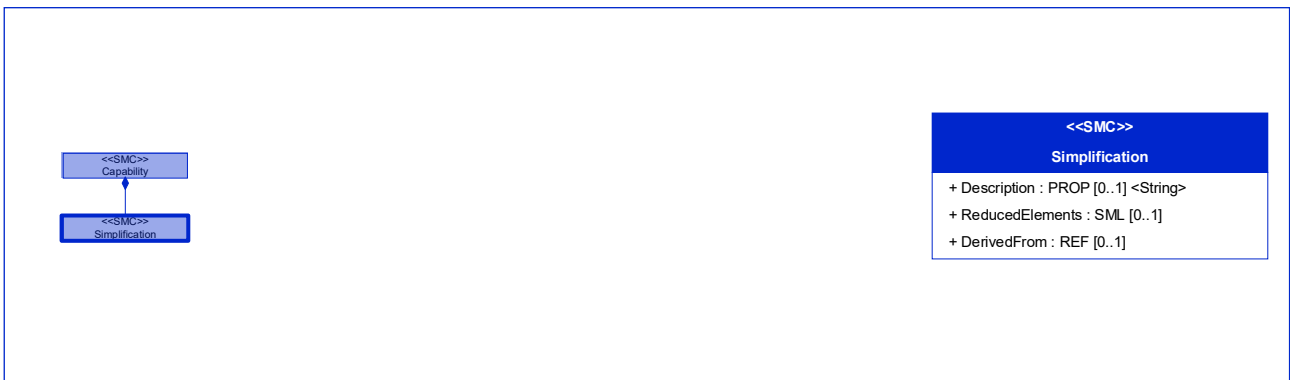

Figure 78: [SML][Prop] ReducedElements

Table 71: [SML][Prop] ReducedElements

<b>idShort:</b>	ReducedElements
<b>Class:</b>	SubmodelElementList [SML] that contains Properties [Prop] [String]
<b>semanticId:</b>	[IRI] <a href="https://admin-shell.io/idta/Models3D/Model3D/Capability/Simplification/ReducedElements/1/0">https://admin-shell.io/idta/Models3D/Model3D/Capability/Simplification/ReducedElements/1/0</a>
<b>Parent:</b>	[IRI] <a href="https://admin-shell.io/idta/Models3D/Model3D/Capability/Simplification/1/0">https://admin-shell.io/idta/Models3D/Model3D/Capability/Simplification/1/0</a> Simplification
<b>Explanation:</b>	List of information about what elements were reduced, in comparison to the model this model was derived from.  Use ValueList – ReducedElements





Figure 81: [SMC] Geometry

Table 73: [SMC] Geometry

<b>idShort:</b>	Geometry		
<b>Class:</b>	SubmodelElementCollection [SMC]		
<b>semanticId:</b>	[IRI] <a href="https://admin-shell.io/idta/Models3D/Model3D/Geometry/1/0">https://admin-shell.io/idta/Models3D/Model3D/Geometry/1/0</a>		
<b>Parent:</b>	[IRI] <a href="https://admin-shell.io/idta/Models3D/Model3D/1/0">https://admin-shell.io/idta/Models3D/Model3D/1/0</a> Model3D		
<b>Explanation:</b>	Basic geometric information of the model.		
<b>[SME type]</b>	<b>semanticId = [idType]value</b>	<b>[valueType]</b>	<b>card.</b>
<b>idShort</b>	<b>Description@en</b>	<b>example</b>	
[Prop]	[IRI] <a href="https://admin-shell.io/idta/Models3D/Model3D/Geometry/Representation/1/0">https://admin-shell.io/idta/Models3D/Model3D/Geometry/Representation/1/0</a>  Geometric representation of the asset. Use ValueList – Representation	[String]  Wire Frame	1
[Prop]	[IRI] <a href="https://admin-shell.io/idta/Models3D/Model3D/Geometry/LengthUnit/1/0">https://admin-shell.io/idta/Models3D/Model3D/Geometry/LengthUnit/1/0</a>  The measurement unit of the length properties within subordinate [Prop] of this [SMC] Geometry.	[String]  mm	1
[SML][SMC]	[IRI] <a href="https://admin-shell.io/idta/Models3D/Model3D/Geometry/CartBoundingBox/1/0">https://admin-shell.io/idta/Models3D/Model3D/Geometry/CartBoundingBox/1/0</a>  List of information about the cartesian bounding boxes of the asset.	[n/a]	0..1
[SML][SMC]	[IRI] <a href="https://admin-shell.io/idta/Models3D/Model3D/Geometry/CartRefSystem/1/0">https://admin-shell.io/idta/Models3D/Model3D/Geometry/CartRefSystem/1/0</a>  List of three cartesian reference systems of the asset.	[n/a]	0..1



Figure 82: [Prop] Representation

Table 74: [Prop] Representation

<b>idShort:</b>	Representation
<b>Class:</b>	Property [Prop] [String]
<b>semanticId:</b>	[IRI] <a href="https://admin-shell.io/idta/Models3D/Model3D/Geometry/Representation/1/0">https://admin-shell.io/idta/Models3D/Model3D/Geometry/Representation/1/0</a>
<b>Parent:</b>	[IRI] <a href="https://admin-shell.io/idta/Models3D/Model3D/Geometry/1/0">https://admin-shell.io/idta/Models3D/Model3D/Geometry/1/0</a> Geometry
<b>Explanation:</b>	Geometric representation of the asset. Use ValueList – Representation

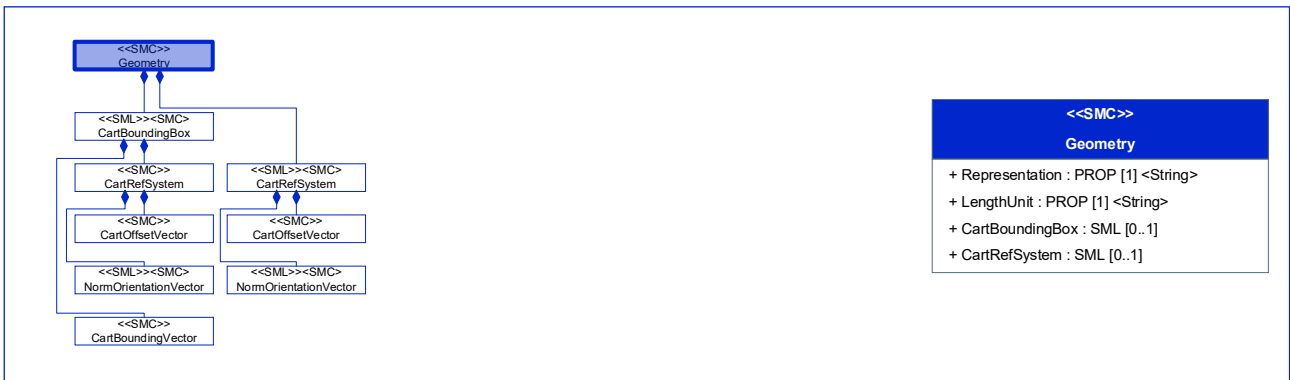

Figure 83: [Prop] LengthUnit

Table 75: [Prop] LengthUnit

<b>idShort:</b>	LengthUnit
<b>Class:</b>	Property [Prop] [String]
<b>semanticId:</b>	[IRI] <a href="https://admin-shell.io/idta/Models3D/Model3D/Geometry/LengthUnit/1/0">https://admin-shell.io/idta/Models3D/Model3D/Geometry/LengthUnit/1/0</a>
<b>Parent:</b>	[IRI] <a href="https://admin-shell.io/idta/Models3D/Model3D/Geometry/1/0">https://admin-shell.io/idta/Models3D/Model3D/Geometry/1/0</a> Geometry
<b>Explanation:</b>	The measurement unit of the length properties within subordinate [Prop] of this [SMC] Geometry.

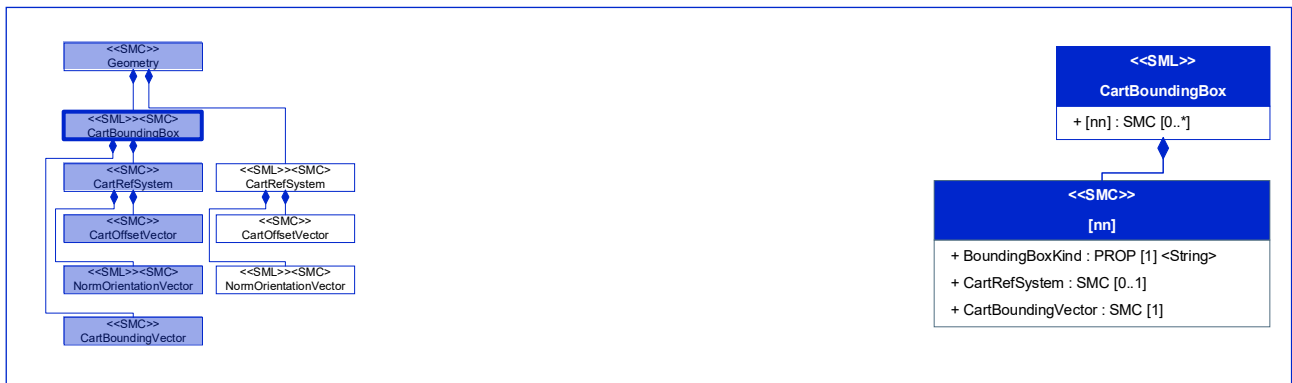

Figure 84: [SML][SMC] CartBoundingBox

Table 76: [SML][SMC] CartBoundingBox

<b>idShort:</b>	CartBoundingBox		
<b>Class:</b>	SubmodelElementList [SML] that contains SubmodelElementCollections [SMC]		
<b>semanticId:</b>	[IRI] <a href="https://admin-shell.io/idta/Models3D/Model3D/Geometry/CartBoundingBox/1/0">https://admin-shell.io/idta/Models3D/Model3D/Geometry/CartBoundingBox/1/0</a>		
<b>Parent:</b>	[IRI] <a href="https://admin-shell.io/idta/Models3D/Model3D/Geometry/1/0">https://admin-shell.io/idta/Models3D/Model3D/Geometry/1/0</a> Geometry		
<b>Explanation:</b>	List of information about the cartesian bounding boxes of the asset.		
<b>[SME type]</b>	<b>semanticId = [idType]value</b>	<b>[valueType]</b>	<b>card.</b>
<b>idShort</b>	<b>Description@en</b>	<b>example</b>	
[Prop] BoundingBoxKind	[IRI] <a href="https://admin-shell.io/idta/Models3D/Model3D/Geometry/CartBoundingBox/BoundingBoxKind/1/0">https://admin-shell.io/idta/Models3D/Model3D/Geometry/CartBoundingBox/BoundingBoxKind/1/0</a>  Information about the kind of bounding box.  Use ValueList – BoundingBoxKind	[String]  MaxEnvelope	1
[SMC] CartRefSystem	[IRI] <a href="https://admin-shell.io/idta/Models3D/Model3D/Geometry/CartBoundingBox/CartRefSystem/1/0">https://admin-shell.io/idta/Models3D/Model3D/Geometry/CartBoundingBox/CartRefSystem/1/0</a>  Cartesian reference system of the bounding box.	[n/a]	0..1
[SMC] CartBoundingVector	[IRI] <a href="https://admin-shell.io/idta/Models3D/Model3D/Geometry/CartBoundingBox/CartBoundingVector/1/0">https://admin-shell.io/idta/Models3D/Model3D/Geometry/CartBoundingBox/CartBoundingVector/1/0</a>  Cartesian vector that describes the expansion of the bounding box from a cartesian reference system (CartRefSystem).	[n/a]	1



Figure 85: [Prop] BoundingBoxKind

Table 77: [Prop] BoundingBoxKind

<b>idShort:</b>	BoundingBoxKind
<b>Class:</b>	Property [Prop] [String]
<b>semanticId:</b>	[IRI] <a href="https://admin-shell.io/idta/Models3D/Model3D/Geometry/CartBoundingBox/BoundingBoxKind/1/0">https://admin-shell.io/idta/Models3D/Model3D/Geometry/CartBoundingBox/BoundingBoxKind/1/0</a>
<b>Parent:</b>	[IRI] <a href="https://admin-shell.io/idta/Models3D/Model3D/Geometry/CartBoundingBox/1/0">https://admin-shell.io/idta/Models3D/Model3D/Geometry/CartBoundingBox/1/0</a> CartBoundingBox
<b>Explanation:</b>	Information about the kind of bounding box. Use ValueList – BoundingBoxKind

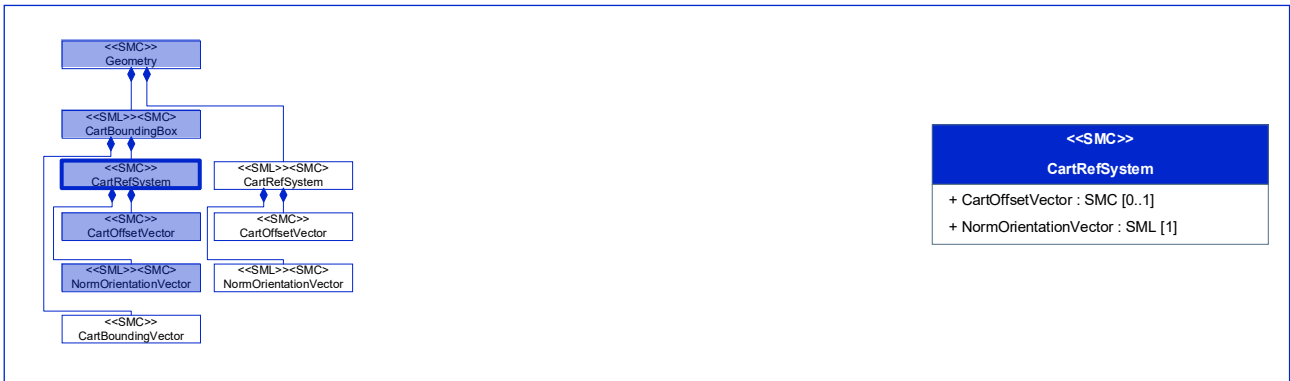

Figure 86: [SMC] CartRefSystem

Table 78: [SMC] CartRefSystem

<b>idShort:</b>	CartRefSystem		
<b>Class:</b>	SubmodelElementCollection [SMC]		
<b>semanticId:</b>	[IRI] <a href="https://admin-shell.io/idta/Models3D/Model3D/Geometry/CartBoundingBox/CartRefSystem/1/0">https://admin-shell.io/idta/Models3D/Model3D/Geometry/CartBoundingBox/CartRefSystem/1/0</a>		
<b>Parent:</b>	[IRI] <a href="https://admin-shell.io/idta/Models3D/Model3D/Geometry/CartBoundingBox/1/0">https://admin-shell.io/idta/Models3D/Model3D/Geometry/CartBoundingBox/1/0</a> CartBoundingBox		
<b>Explanation:</b>	Cartesian reference system of the cart bounding box of the Asset.		
<b>[SME type]</b>	<b>semanticId = [idType]value</b>	<b>[valueType]</b>	<b>card.</b>
<b>idShort</b>	<b>Description@en</b>	<b>example</b>	
[SMC] CartOffsetVector	[IRI] <a href="https://admin-shell.io/idta/Models3D/Model3D/Geometry/CartBoundingBox/CartRefSystem/CartOffsetVector/1/0">https://admin-shell.io/idta/Models3D/Model3D/Geometry/CartBoundingBox/CartRefSystem/CartOffsetVector/1/0</a>  Cartesian offset vector of the cartesian reference system	[n/a]	0..1
[SMC] NormOrientationVector	[IRI] <a href="https://admin-shell.io/idta/Models3D/Model3D/Geometry/CartBoundingBox/CartRefSystem/NormOrientationVector/1/0">https://admin-shell.io/idta/Models3D/Model3D/Geometry/CartBoundingBox/CartRefSystem/NormOrientationVector/1/0</a>  Cartesian norm vector of the cartesian reference system	[n/a]	3



Figure 87: [SMC] CartOffsetVector

Table 79: [SMC] CartOffsetVector

<b>idShort:</b>	CartOffsetVector		
<b>Class:</b>	SubmodelElementCollection [SMC]		
<b>semanticId:</b>	[IRI] <a href="https://admin-shell.io/idta/Models3D/Model3D/Geometry/CartBoundingBox/CartRefSystem/CartOffsetVector/1/0">https://admin-shell.io/idta/Models3D/Model3D/Geometry/CartBoundingBox/CartRefSystem/CartOffsetVector/1/0</a>		
<b>Parent:</b>	[IRI] <a href="https://admin-shell.io/idta/Models3D/Model3D/Geometry/CartBoundingBox/CartRefSystem/1/0">https://admin-shell.io/idta/Models3D/Model3D/Geometry/CartBoundingBox/CartRefSystem/1/0</a> CartRefSystem		
<b>Explanation:</b>	Cartesian offset vector of the cartesian reference system		
<b>[SME type]</b>	<b>semanticId = [idType]value</b>	<b>[valueType]</b>	<b>card.</b>
<b>idShort</b>	<b>Description@en</b>	<b>example</b>	
[Prop] X	[IRI] <a href="https://admin-shell.io/idta/Models3D/Model3D/Geometry/CartBoundingBox/CartRefSystem/CartOffsetVector/X/1/0">https://admin-shell.io/idta/Models3D/Model3D/Geometry/CartBoundingBox/CartRefSystem/CartOffsetVector/X/1/0</a>  X component of the offset vector. Always state the unit.	[Double]  42	1
[Prop] Y	[IRI] <a href="https://admin-shell.io/idta/Models3D/Model3D/Geometry/CartBoundingBox/CartRefSystem/CartOffsetVector/Y/1/0">https://admin-shell.io/idta/Models3D/Model3D/Geometry/CartBoundingBox/CartRefSystem/CartOffsetVector/Y/1/0</a>  Y component of the offset vector. Always state the unit.	[Double]  42	1
[Prop] Z	[IRI] <a href="https://admin-shell.io/idta/Models3D/Model3D/Geometry/CartBoundingBox/CartRefSystem/CartOffsetVector/Z/1/0">https://admin-shell.io/idta/Models3D/Model3D/Geometry/CartBoundingBox/CartRefSystem/CartOffsetVector/Z/1/0</a>  Z component of the offset vector. Always state the unit.	[Double]  42	1

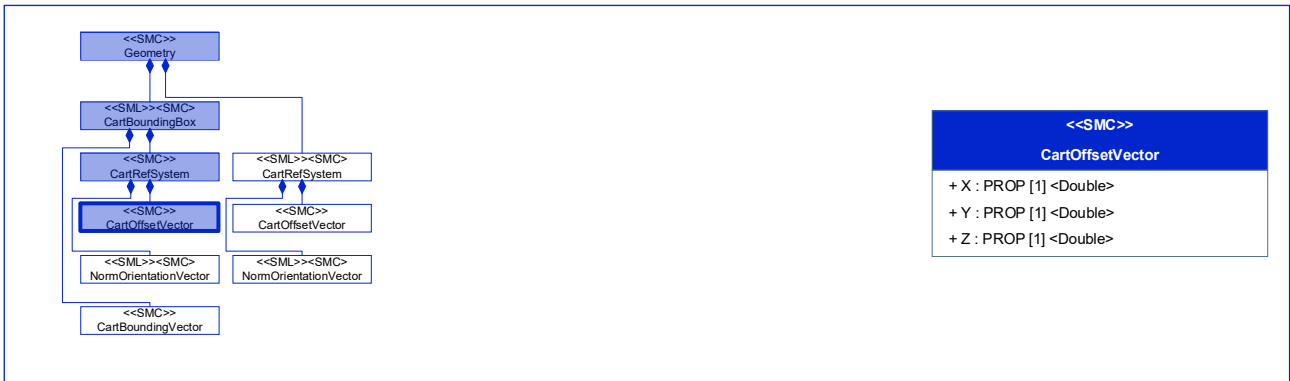

Figure 88: [Prop] X

Table 80: [Prop] X

<b>idShort:</b>	X
<b>Class:</b>	Property [Prop] [Double]
<b>semanticId:</b>	[IRI] <a href="https://admin-shell.io/idta/Models3D/Model3D/Geometry/CartBoundingBox/CartRefSystem/CartOffsetVector/X/1/0">https://admin-shell.io/idta/Models3D/Model3D/Geometry/CartBoundingBox/CartRefSystem/CartOffsetVector/X/1/0</a>
<b>Parent:</b>	[IRI] <a href="https://admin-shell.io/idta/Models3D/Model3D/Geometry/CartBoundingBox/CartRefSystem/CartOffsetVector/1/0">https://admin-shell.io/idta/Models3D/Model3D/Geometry/CartBoundingBox/CartRefSystem/CartOffsetVector/1/0</a> CartOffsetVector
<b>Explanation:</b>	X component of the offset vector. Always state the unit.



Figure 89: [Prop] Y

Table 81: [Prop] Y

<b>idShort:</b>	Y
<b>Class:</b>	Property [Prop] [Double]
<b>semanticId:</b>	[IRI] <a href="https://admin-shell.io/idta/Models3D/Model3D/Geometry/CartBoundingBox/CartRefSystem/CartOffsetVector/Y/1/0">https://admin-shell.io/idta/Models3D/Model3D/Geometry/CartBoundingBox/CartRefSystem/CartOffsetVector/Y/1/0</a>
<b>Parent:</b>	[IRI] <a href="https://admin-shell.io/idta/Models3D/Model3D/Geometry/CartBoundingBox/CartRefSystem/CartOffsetVector/1/0">https://admin-shell.io/idta/Models3D/Model3D/Geometry/CartBoundingBox/CartRefSystem/CartOffsetVector/1/0</a> CartOffsetVector
<b>Explanation:</b>	Y component of the offset vector. Always state the unit.

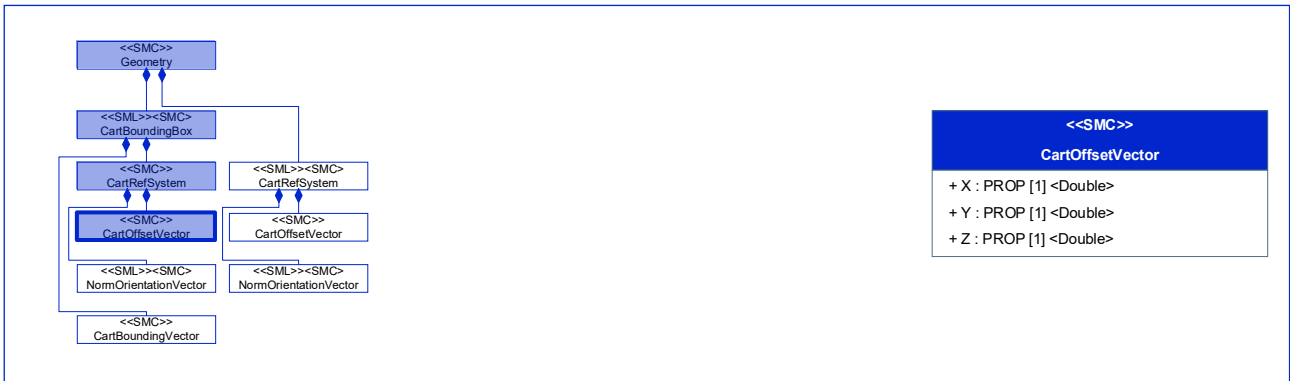

Figure 90: [Prop] Z

Table 82: [Prop] Z

<b>idShort:</b>	Z
<b>Class:</b>	Property [Prop] [Double]
<b>semanticId:</b>	[IRI] <a href="https://admin-shell.io/idta/Models3D/Model3D/Geometry/CartBoundingBox/CartRefSystem/CartOffsetVector/Z/1/0">https://admin-shell.io/idta/Models3D/Model3D/Geometry/CartBoundingBox/CartRefSystem/CartOffsetVector/Z/1/0</a>
<b>Parent:</b>	[IRI] <a href="https://admin-shell.io/idta/Models3D/Model3D/Geometry/CartBoundingBox/CartRefSystem/CartOffsetVector/1/0">https://admin-shell.io/idta/Models3D/Model3D/Geometry/CartBoundingBox/CartRefSystem/CartOffsetVector/1/0</a> CartOffsetVector
<b>Explanation:</b>	Z component of the offset vector. Always state the unit.



Figure 91: [SML][SMC] NormOrientationVector

Table 83: [SML][SMC] NormOrientationVector

<b>idShort:</b>	NormOrientationVector		
<b>Class:</b>	SubmodelElementList [SML] that contains SubmodelElementCollections [SMC]		
<b>semanticId:</b>	[IRI] <a href="https://admin-shell.io/idta/Models3D/Model3D/Geometry/CartBoundingBox/CartRefSystem/NormOrientationVector/1/0">https://admin-shell.io/idta/Models3D/Model3D/Geometry/CartBoundingBox/CartRefSystem/NormOrientationVector/1/0</a>		
<b>Parent:</b>	[IRI] <a href="https://admin-shell.io/idta/Models3D/Model3D/Geometry/CartBoundingBox/CartRefSystem/1/0">https://admin-shell.io/idta/Models3D/Model3D/Geometry/CartBoundingBox/CartRefSystem/1/0</a> CartRefSystem		
<b>Explanation:</b>	List with three cartesian norm vectors of the cartesian reference system		
<b>[SME type]</b>	<b>semanticId = [idType]value</b>	<b>[valueType]</b>	<b>card.</b>
<b>idShort</b>	<b>Description@en</b>	<b>example</b>	
[Prop] X	[IRI] <a href="https://admin-shell.io/idta/Models3D/Model3D/Geometry/CartBoundingBox/CartRefSystem/NormOrientationVector/X/1/0">https://admin-shell.io/idta/Models3D/Model3D/Geometry/CartBoundingBox/CartRefSystem/NormOrientationVector/X/1/0</a>  X component of the norm vector.  Always state the unit.	[Double]  42	1
[Prop] Y	[IRI] <a href="https://admin-shell.io/idta/Models3D/Model3D/Geometry/CartBoundingBox/CartRefSystem/NormOrientationVector/Y/1/0">https://admin-shell.io/idta/Models3D/Model3D/Geometry/CartBoundingBox/CartRefSystem/NormOrientationVector/Y/1/0</a>  Y component of the norm vector.  Always state the unit.	[Double]  42	1
[Prop] Z	[IRI] <a href="https://admin-shell.io/idta/Models3D/Model3D/Geometry/CartBoundingBox/CartRefSystem/NormOrientationVector/Z/1/0">https://admin-shell.io/idta/Models3D/Model3D/Geometry/CartBoundingBox/CartRefSystem/NormOrientationVector/Z/1/0</a>  Z component of the norm vector.  Always state the unit.	[Double]  42	1

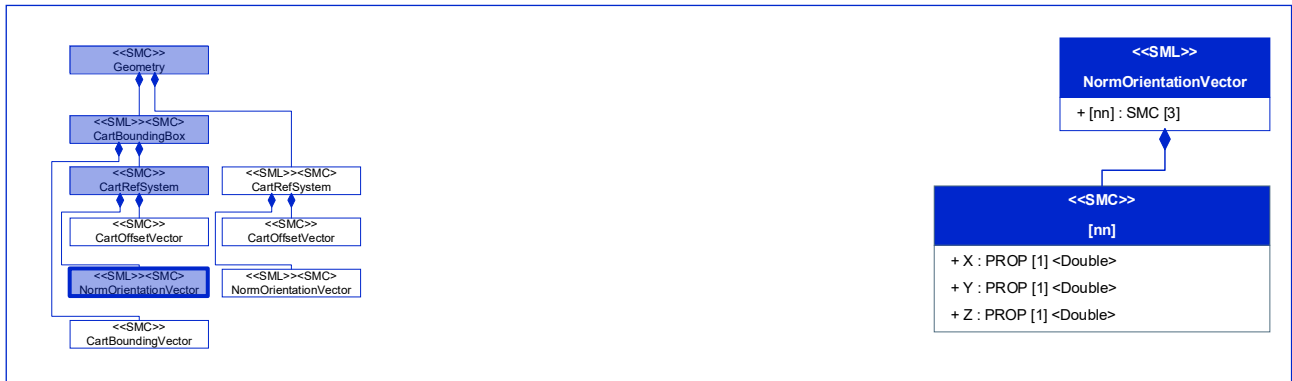

Figure 92: [Prop] X

Table 84: [Prop] X

<b>idShort:</b>	X
<b>Class:</b>	Property [Prop] [Double]
<b>semanticId:</b>	[IRI] <a href="https://admin-shell.io/idta/Models3D/Model3D/Geometry/CartBoundingBox/CartRefSystem/NormOrientationVector/X/1/0">https://admin-shell.io/idta/Models3D/Model3D/Geometry/CartBoundingBox/CartRefSystem/NormOrientationVector/X/1/0</a>
<b>Parent:</b>	[IRI] <a href="https://admin-shell.io/idta/Models3D/Model3D/Geometry/CartBoundingBox/CartRefSystem/NormOrientationVector/1/0">https://admin-shell.io/idta/Models3D/Model3D/Geometry/CartBoundingBox/CartRefSystem/NormOrientationVector/1/0</a> NormOrientationVector
<b>Explanation:</b>	X component of the norm vector. Always state the unit.



Figure 93: [Prop] Y

Table 85: [Prop] Y

<b>idShort:</b>	Y
<b>Class:</b>	Property [Prop] [Double]
<b>semanticId:</b>	[IRI] <a href="https://admin-shell.io/idta/Models3D/Model3D/Geometry/CartBoundingBox/CartRefSystem/NormOrientationVector/Y/1/0">https://admin-shell.io/idta/Models3D/Model3D/Geometry/CartBoundingBox/CartRefSystem/NormOrientationVector/Y/1/0</a>
<b>Parent:</b>	[IRI] <a href="https://admin-shell.io/idta/Models3D/Model3D/Geometry/CartBoundingBox/CartRefSystem/NormOrientationVector/1/0">https://admin-shell.io/idta/Models3D/Model3D/Geometry/CartBoundingBox/CartRefSystem/NormOrientationVector/1/0</a> NormOrientationVector
<b>Explanation:</b>	Y component of the norm vector. Always state the unit.



Figure 94: [Prop] Z

Table 86: [Prop] Z

<b>idShort:</b>	Z
<b>Class:</b>	Property [Prop] [Double]
<b>semanticId:</b>	[IRI] <a href="https://admin-shell.io/idta/Models3D/Model3D/Geometry/CartBoundingBox/CartRefSystem/NormOrientationVector/Z/1/0">https://admin-shell.io/idta/Models3D/Model3D/Geometry/CartBoundingBox/CartRefSystem/NormOrientationVector/Z/1/0</a>
<b>Parent:</b>	[IRI] <a href="https://admin-shell.io/idta/Models3D/Model3D/Geometry/CartBoundingBox/CartRefSystem/NormOrientationVector/1/0">https://admin-shell.io/idta/Models3D/Model3D/Geometry/CartBoundingBox/CartRefSystem/NormOrientationVector/1/0</a> NormOrientationVector
<b>Explanation:</b>	Z component of the norm vector. Always state the unit.



Figure 95: [SMC] CartBoundingBox

Table 87: [SMC] CartBoundingBoxVector

<b>idShort:</b>	CartBoundingBoxVector		
<b>Class:</b>	SubmodelElementCollection [SMC]		
<b>semanticId:</b>	[IRI] <a href="https://admin-shell.io/idta/Models3D/Model3D/Geometry/CartBoundingBox/CartBoundingBoxVector/1/0">https://admin-shell.io/idta/Models3D/Model3D/Geometry/CartBoundingBox/CartBoundingBoxVector/1/0</a>		
<b>Parent:</b>	[IRI] <a href="https://admin-shell.io/idta/Models3D/Model3D/Geometry/CartBoundingBox/1/0">https://admin-shell.io/idta/Models3D/Model3D/Geometry/CartBoundingBox/1/0</a> CartBoundingBox		
<b>Explanation:</b>	Cartesian vector that describes the expansion of the bounding box from a cartesian reference system (CartRefSystem).		
<b>[SME type]</b>	<b>semanticId = [idType]value</b>	<b>[valueType]</b>	<b>card.</b>
<b>idShort</b>	<b>Description@en</b>	<b>example</b>	
[Prop] X	[IRI] <a href="https://admin-shell.io/idta/Models3D/Model3D/Geometry/CartBoundingBox/CartBoundingBoxVector/X/1/0">https://admin-shell.io/idta/Models3D/Model3D/Geometry/CartBoundingBox/CartBoundingBoxVector/X/1/0</a>  X component of the bounding vector.  Always state the unit.	[Double]  42	1
[Prop] Y	[IRI] <a href="https://admin-shell.io/idta/Models3D/Model3D/Geometry/CartBoundingBox/CartBoundingBoxVector/Y/1/0">https://admin-shell.io/idta/Models3D/Model3D/Geometry/CartBoundingBox/CartBoundingBoxVector/Y/1/0</a>  Y component of the bounding vector.  Always state the unit.	[Double]  42	1
[Prop] Z	[IRI] <a href="https://admin-shell.io/idta/Models3D/Model3D/Geometry/CartBoundingBox/CartBoundingBoxVector/Z/1/0">https://admin-shell.io/idta/Models3D/Model3D/Geometry/CartBoundingBox/CartBoundingBoxVector/Z/1/0</a>  Z component of the bounding vector.  Always state the unit.	[Double]  42	1

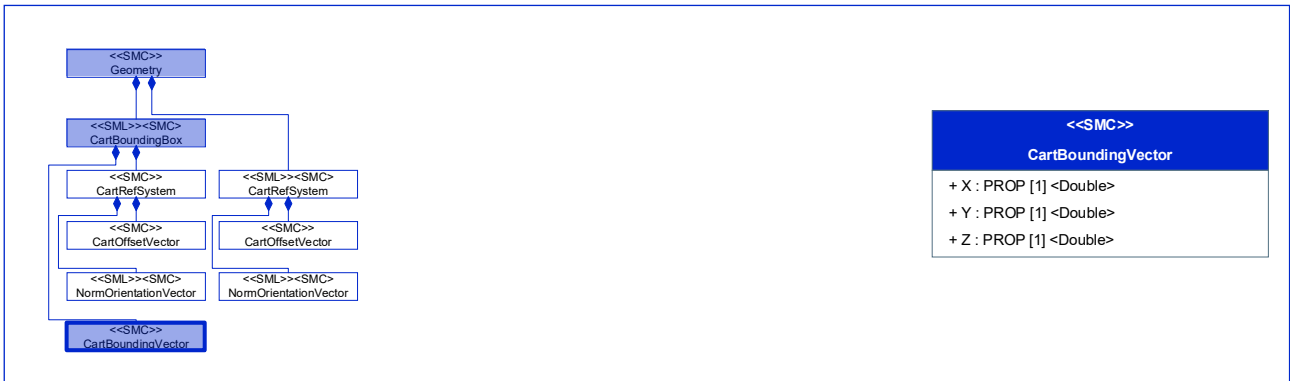

Figure 96: [Prop] X

Table 88: [Prop] X

<b>idShort:</b>	X
<b>Class:</b>	Property [Prop] [Double]
<b>semanticId:</b>	[IRI] <a href="https://admin-shell.io/idta/Models3D/Model3D/Geometry/CartBoundingBox/CartBoundingVector/X/1/0">https://admin-shell.io/idta/Models3D/Model3D/Geometry/CartBoundingBox/CartBoundingVector/X/1/0</a>
<b>Parent:</b>	[IRI] <a href="https://admin-shell.io/idta/Models3D/Model3D/Geometry/CartBoundingBox/CartBoundingVector/1/0">https://admin-shell.io/idta/Models3D/Model3D/Geometry/CartBoundingBox/CartBoundingVector/1/0</a> CartBoundingVector
<b>Explanation:</b>	X component of the bounding vector. Always state the unit.



Figure 97: [Prop] Y

Table 89: [Prop] Y

<b>idShort:</b>	Y
<b>Class:</b>	Property [Prop] [Double]
<b>semanticId:</b>	[IRI] <a href="https://admin-shell.io/idta/Models3D/Model3D/Geometry/CartBoundingBox/CartBoundingVector/Y/1/0">https://admin-shell.io/idta/Models3D/Model3D/Geometry/CartBoundingBox/CartBoundingVector/Y/1/0</a>
<b>Parent:</b>	[IRI] <a href="https://admin-shell.io/idta/Models3D/Model3D/Geometry/CartBoundingBox/CartBoundingVector/1/0">https://admin-shell.io/idta/Models3D/Model3D/Geometry/CartBoundingBox/CartBoundingVector/1/0</a> CartBoundingVector
<b>Explanation:</b>	Y component of the bounding vector. Always state the unit.

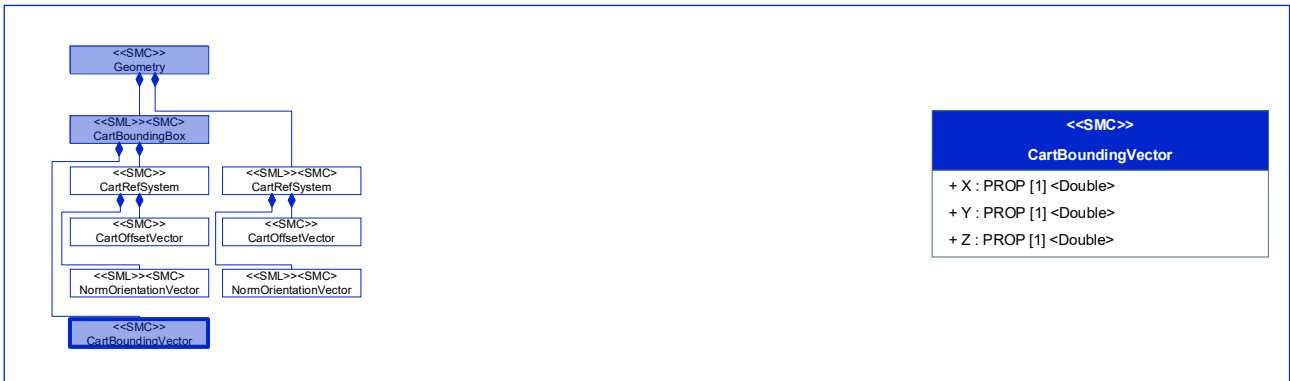

Figure 98: [Prop] Z

Table 90: [Prop] Z

<b>idShort:</b>	Z
<b>Class:</b>	Property [Prop] [Double]
<b>semanticId:</b>	[IRI] <a href="https://admin-shell.io/idta/Models3D/Model3D/Geometry/CartBoundingBox/CartBoundingVector/Z/1/0">https://admin-shell.io/idta/Models3D/Model3D/Geometry/CartBoundingBox/CartBoundingVector/Z/1/0</a>
<b>Parent:</b>	[IRI] <a href="https://admin-shell.io/idta/Models3D/Model3D/Geometry/CartBoundingBox/CartBoundingVector/1/0">https://admin-shell.io/idta/Models3D/Model3D/Geometry/CartBoundingBox/CartBoundingVector/1/0</a> CartBoundingVector
<b>Explanation:</b>	Z component of the bounding vector. Always state the unit.



Figure 99: [SML][SMC] CartRefSystem

Table 91: [SML][SMC] CartRefSystem

<b>idShort:</b>	CartRefSystem		
<b>Class:</b>	SubmodelElementList [SML] that contains SubmodelElementCollections [SMC]		
<b>semanticId:</b>	[IRI] <a href="https://admin-shell.io/idta/Models3D/Model3D/Geometry/CartRefSystem/1/0">https://admin-shell.io/idta/Models3D/Model3D/Geometry/CartRefSystem/1/0</a>		
<b>Parent:</b>	[IRI] <a href="https://admin-shell.io/idta/Models3D/Model3D/Geometry/1/0">https://admin-shell.io/idta/Models3D/Model3D/Geometry/1/0</a> Geometry		
<b>Explanation:</b>	List of cartesian reference system.		
<b>[SME type]</b>	<b>semanticId = [idType]value</b>	<b>[valueType]</b>	<b>card.</b>
<b>idShort</b>	<b>Description@en</b>	<b>example</b>	
[SMC] CartOffsetVector	[IRI] <a href="https://admin-shell.io/idta/Models3D/Model3D/Geometry/CartRefSystem/CartOffsetVector/1/0">https://admin-shell.io/idta/Models3D/Model3D/Geometry/CartRefSystem/CartOffsetVector/1/0</a>  Cartesian offset vector of the cartesian reference system	[n/a]	0..1
[SML][SMC] NormOrientationVector	[IRI] <a href="https://admin-shell.io/idta/Models3D/Model3D/Geometry/CartRefSystem/NormOrientationVector/1/0">https://admin-shell.io/idta/Models3D/Model3D/Geometry/CartRefSystem/NormOrientationVector/1/0</a>  List of three cartesian norm vectors of the cartesian reference system	[n/a]	1



Figure 100: [SMC] CartOffsetVector

Table 92: [SMC] CartOffsetVector

<b>idShort:</b>	CartOffsetVector		
<b>Class:</b>	SubmodelElementCollection [SMC]		
<b>semanticId:</b>	[IRI] <a href="https://admin-shell.io/idta/Models3D/Model3D/Geometry/CartRefSystem/CartOffsetVector/1/0">https://admin-shell.io/idta/Models3D/Model3D/Geometry/CartRefSystem/CartOffsetVector/1/0</a>		
<b>Parent:</b>	[IRI] <a href="https://admin-shell.io/idta/Models3D/Model3D/Geometry/CartRefSystem/1/0">https://admin-shell.io/idta/Models3D/Model3D/Geometry/CartRefSystem/1/0</a> CartRefSystem		
<b>Explanation:</b>	Cartesian offset vector of the cartesian reference system		
<b>[SME type]</b>	<b>semanticId = [idType]value</b>	<b>[valueType]</b>	<b>card.</b>
<b>idShort</b>	<b>Description@en</b>	<b>example</b>	
[Prop] X	[IRI] <a href="https://admin-shell.io/idta/Models3D/Model3D/Geometry/CartRefSystem/CartOffsetVector/X/1/0">https://admin-shell.io/idta/Models3D/Model3D/Geometry/CartRefSystem/CartOffsetVector/X/1/0</a>  X component of the reference vector.  Always state the unit.	[Double] 42	1
[Prop] Y	[IRI] <a href="https://admin-shell.io/idta/Models3D/Model3D/Geometry/CartRefSystem/CartOffsetVector/Y/1/0">https://admin-shell.io/idta/Models3D/Model3D/Geometry/CartRefSystem/CartOffsetVector/Y/1/0</a>  Y component of the reference vector.  Always state the unit.	[Double] 42	1
[Prop] Z	[IRI] <a href="https://admin-shell.io/idta/Models3D/Model3D/Geometry/CartRefSystem/CartOffsetVector/Z/1/0">https://admin-shell.io/idta/Models3D/Model3D/Geometry/CartRefSystem/CartOffsetVector/Z/1/0</a>  Z component of the reference vector.  Always state the unit.	[Double] 42	1



Figure 101: [Prop] X

Table 93: [Prop] X

<b>idShort:</b>	X
<b>Class:</b>	Property [Prop] [Double]
<b>semanticId:</b>	[IRI] <a href="https://admin-shell.io/idta/Models3D/Model3D/Geometry/CartRefSystem/CartOffsetVector/X/1/0">https://admin-shell.io/idta/Models3D/Model3D/Geometry/CartRefSystem/CartOffsetVector/X/1/0</a>
<b>Parent:</b>	[IRI] <a href="https://admin-shell.io/idta/Models3D/Model3D/Geometry/CartRefSystem/CartOffsetVector/1/0">https://admin-shell.io/idta/Models3D/Model3D/Geometry/CartRefSystem/CartOffsetVector/1/0</a> CartOffsetVector
<b>Explanation:</b>	X component of the reference vector. Always state the unit.

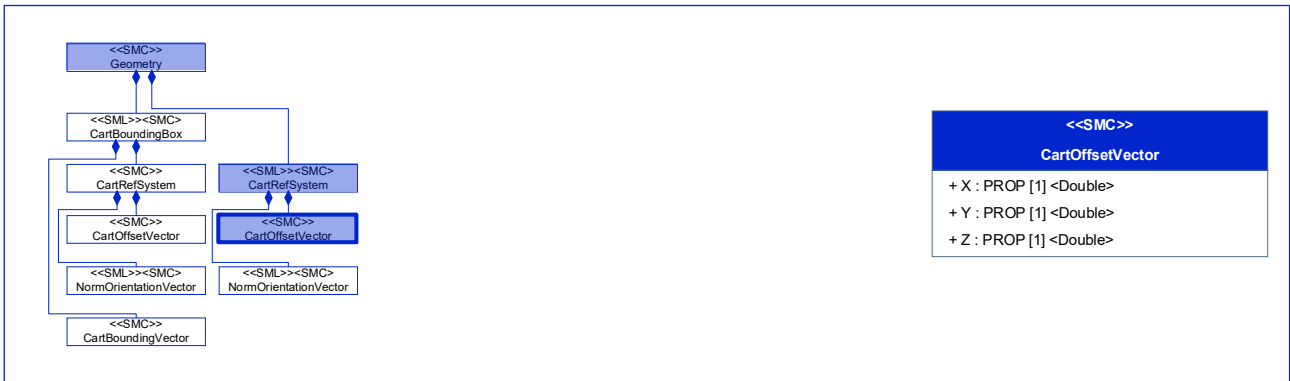

Figure 102: [Prop] Y

Table 94: [Prop] Y

<b>idShort:</b>	Y
<b>Class:</b>	Property [Prop] [Double]
<b>semanticId:</b>	[IRI] <a href="https://admin-shell.io/idta/Models3D/Model3D/Geometry/CartRefSystem/CartOffsetVector/Y/1/0">https://admin-shell.io/idta/Models3D/Model3D/Geometry/CartRefSystem/CartOffsetVector/Y/1/0</a>
<b>Parent:</b>	[IRI] <a href="https://admin-shell.io/idta/Models3D/Model3D/Geometry/CartRefSystem/CartOffsetVector/1/0">https://admin-shell.io/idta/Models3D/Model3D/Geometry/CartRefSystem/CartOffsetVector/1/0</a> CartOffsetVector
<b>Explanation:</b>	Y component of the reference vector. Always state the unit.

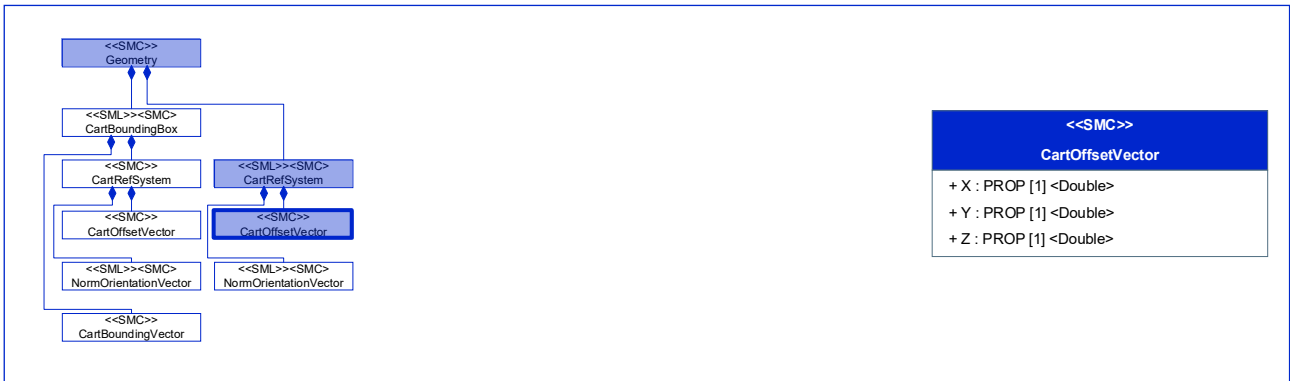

Figure 103: [Prop] Z

Table 95: [Prop] Z

<b>idShort:</b>	Z
<b>Class:</b>	Property [Prop] [Double]
<b>semanticId:</b>	[IRI] <a href="https://admin-shell.io/idta/Models3D/Model3D/Geometry/CartRefSystem/CartOffsetVector/Z/1/0">https://admin-shell.io/idta/Models3D/Model3D/Geometry/CartRefSystem/CartOffsetVector/Z/1/0</a>
<b>Parent:</b>	[IRI] <a href="https://admin-shell.io/idta/Models3D/Model3D/Geometry/CartRefSystem/CartOffsetVector/1/0">https://admin-shell.io/idta/Models3D/Model3D/Geometry/CartRefSystem/CartOffsetVector/1/0</a> CartOffsetVector
<b>Explanation:</b>	Z component of the reference vector. Always state the unit.



Figure 104: [SML][SMC] NormOrientationVector

Table 96: [SML][SMC] NormOrientationVector

<b>idShort:</b>	NormOrientationVector		
<b>Class:</b>	SubmodelElementList [SML] that contains SubmodelElementCollections [SMC]		
<b>semanticId:</b>	[IRI] <a href="https://admin-shell.io/idta/Models3D/Model3D/Geometry/CartRefSystem/NormOrientationVector/1/0">https://admin-shell.io/idta/Models3D/Model3D/Geometry/CartRefSystem/NormOrientationVector/1/0</a>		
<b>Parent:</b>	[IRI] <a href="https://admin-shell.io/idta/Models3D/Model3D/Geometry/CartRefSystem/1/0">https://admin-shell.io/idta/Models3D/Model3D/Geometry/CartRefSystem/1/0</a> CartRefSystem		
<b>Explanation:</b>	List of three norm orientation vectors of the cartesian reference system.		
<b>[SME type]</b>	<b>semanticId = [idType]value</b>	<b>[valueType]</b>	<b>card.</b>
<b>idShort</b>	<b>Description@en</b>	<b>example</b>	
[Prop] X	[IRI] <a href="https://admin-shell.io/idta/Models3D/Model3D/Geometry/CartRefSystem/NormOrientationVector/X/1/0">https://admin-shell.io/idta/Models3D/Model3D/Geometry/CartRefSystem/NormOrientationVector/X/1/0</a>  X component of the norm vector. Always state the unit.	[Double] 42	1
[Prop] Y	[IRI] <a href="https://admin-shell.io/idta/Models3D/Model3D/Geometry/CartRefSystem/NormOrientationVector/Y/1/0">https://admin-shell.io/idta/Models3D/Model3D/Geometry/CartRefSystem/NormOrientationVector/Y/1/0</a>  Y component of the norm vector. Always state the unit.	[Double] 42	1
[Prop] Z	[IRI] <a href="https://admin-shell.io/idta/Models3D/Model3D/Geometry/CartRefSystem/NormOrientationVector/Z/1/0">https://admin-shell.io/idta/Models3D/Model3D/Geometry/CartRefSystem/NormOrientationVector/Z/1/0</a>  Z component of the norm vector. Always state the unit.	[Double] 42	1



Figure 105: [Prop] X

Table 97: [Prop] X

<b>idShort:</b>	X
<b>Class:</b>	Property [Prop] [Double]
<b>semanticId:</b>	[IRI] <a href="https://admin-shell.io/idta/Models3D/Model3D/Geometry/CartRefSystem/NormOrientationVector/X/1/0">https://admin-shell.io/idta/Models3D/Model3D/Geometry/CartRefSystem/NormOrientationVector/X/1/0</a>
<b>Parent:</b>	[IRI] <a href="https://admin-shell.io/idta/Models3D/Model3D/Geometry/CartRefSystem/NormOrientationVector/1/0">https://admin-shell.io/idta/Models3D/Model3D/Geometry/CartRefSystem/NormOrientationVector/1/0</a> NormOrientationVector
<b>Explanation:</b>	X component of the norm vector. Always state the unit.



Figure 106: [Prop] Y

Table 98: [Prop] Y

<b>idShort:</b>	Y
<b>Class:</b>	Property [Prop] [Double]
<b>semanticId:</b>	[IRI] <a href="https://admin-shell.io/idta/Models3D/Model3D/Geometry/CartRefSystem/NormOrientationVector/Y/1/0">https://admin-shell.io/idta/Models3D/Model3D/Geometry/CartRefSystem/NormOrientationVector/Y/1/0</a>
<b>Parent:</b>	[IRI] <a href="https://admin-shell.io/idta/Models3D/Model3D/Geometry/CartRefSystem/NormOrientationVector/1/0">https://admin-shell.io/idta/Models3D/Model3D/Geometry/CartRefSystem/NormOrientationVector/1/0</a> NormOrientationVector
<b>Explanation:</b>	Y component of the norm vector. Always state the unit.



Figure 107: [Prop] Z

Table 99: [Prop] Z

<b>idShort:</b>	Z
<b>Class:</b>	Property [Prop] [Double]
<b>semanticId:</b>	[IRI] <a href="https://admin-shell.io/idta/Models3D/Model3D/Geometry/CartRefSystem/NormOrientationVector/Z/1/0">https://admin-shell.io/idta/Models3D/Model3D/Geometry/CartRefSystem/NormOrientationVector/Z/1/0</a>
<b>Parent:</b>	[IRI] <a href="https://admin-shell.io/idta/Models3D/Model3D/Geometry/CartRefSystem/NormOrientationVector/1/0">https://admin-shell.io/idta/Models3D/Model3D/Geometry/CartRefSystem/NormOrientationVector/1/0</a> NormOrientationVector
<b>Explanation:</b>	Z component of the norm vector. Always state the unit.

## 2.3 Predefined ValueLists

This chapter contains the detailed description of predefined values that should be used for the properties in the SM. The values are grouped into value lists with the same name as the corresponding properties.

Figure 108 shows the overview of the Value Lists for the [SM] “Model3D”.

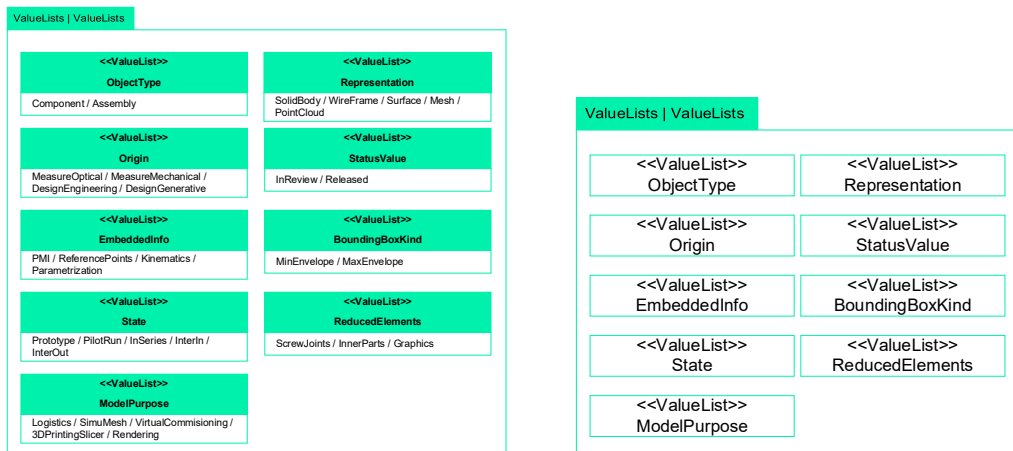

Figure 108: Predefined ValueLists – Overview



Figure 109: ValueList – ObjectType

Table 100: ValueList – ObjectType

<b>idShort:</b>	ObjectType	
<b>Class:</b>	Property [Prop] [String]	
<b>semanticId:</b>	[IRI] <a href="https://admin-shell.io/idta/Models3D/Model3D/Capability/ObjectType/1/0">https://admin-shell.io/idta/Models3D/Model3D/Capability/ObjectType/1/0</a>	
<b>Parent:</b>	[IRI] <a href="https://admin-shell.io/idta/Models3D/Model3D/Capability/1/0">https://admin-shell.io/idta/Models3D/Model3D/Capability/1/0</a> Capability	
<b>Explanation:</b>	Object type in terms of CAD structure.	
-	-	<b>semanticId = [idType]value</b>
<b>Preferred Name</b>	<b>Description@en</b>	<b>Dictionary / Classification System</b>
Component	The 3D model file represents a single component.	[n/a] n/a
Assembly	The 3D model file represents an assembly of assemblies or single components.	[n/a] n/a



**Figure 110: ValueList – Origin**

**Table 101: ValueList – Origin**

<b>idShort:</b>	Origin	
<b>Class:</b>	Property [Prop] [String]	
<b>semanticId:</b>	[IRI] <a href="https://admin-shell.io/idta/Models3D/Model3D/Capability/Origin/1/0">https://admin-shell.io/idta/Models3D/Model3D/Capability/Origin/1/0</a>	
<b>Parent:</b>	[IRI] <a href="https://admin-shell.io/idta/Models3D/Model3D/Capability/1/0">https://admin-shell.io/idta/Models3D/Model3D/Capability/1/0</a> Capability	
<b>Explanation:</b>	Origin on which the model is based on.	
-	-	<b>semanticId = [idType]value</b>
<b>Preferred Name</b>	<b>Description@en</b>	<b>Dictionary / Classification System</b>
MeasureOptical	The origin of the 3D Model is an optical measurement.	[n/a] n/a
Measuremechanical	The origin of the 3D Model is a mechanical measurement.	[n/a] n/a
DesignEngineering	The origin of the 3D Model is an engineering design.	[n/a] n/a
DesignGenerative	The origin of the 3D Model is a generative design.	[n/a] n/a



**Figure 111: ValueList – EmbeddedInfo**

**Table 102: ValueList – EmbeddedInfo**

<b>idShort:</b>	EmbeddedInfo	
<b>Class:</b>	Property [Prop] [String]	
<b>semanticId:</b>	[IRI] <a href="https://admin-shell.io/idta/Models3D/Model3D/Capability/EmbeddedInfo/1/0">https://admin-shell.io/idta/Models3D/Model3D/Capability/EmbeddedInfo/1/0</a>	
<b>Parent:</b>	[IRI] <a href="https://admin-shell.io/idta/Models3D/Model3D/Capability/1/0">https://admin-shell.io/idta/Models3D/Model3D/Capability/1/0</a> Capability	
<b>Explanation:</b>	Further information that are embedded in the 3D model file itself.	
-	-	<b>semanticId = [idType]value</b>
<b>Preferred Name</b>	<b>Description@en</b>	<b>Dictionary / Classification System</b>
PMI	PMI (product and manufacturing information) are embedded in the model file.	[n/a] n/a
ReferencePoints	Reference points are embedded in the model file.	[n/a] n/a
Kinematics	Model has axis with degrees of freedom that are intended for kinematics.	[n/a] n/a
Parametrization	At least one geometric parameter is intended to be set by a parametrization rule.	[n/a] n/a



Figure 112: ValueList – State

Table 103: ValueList – State

<b>idShort:</b>	State	
<b>Class:</b>	Property [Prop] [String]	
<b>semanticId:</b>	[IRI] <a href="https://admin-shell.io/idta/Models3D/Model3D/Capability/State/1/0">https://admin-shell.io/idta/Models3D/Model3D/Capability/State/1/0</a>	
<b>Parent:</b>	[IRI] <a href="https://admin-shell.io/idta/Models3D/Model3D/Capability/1/0">https://admin-shell.io/idta/Models3D/Model3D/Capability/1/0</a> Capability	
<b>Explanation:</b>	State in the products lifecycle which is represented by the model.	
-	-	semanticId = [idType]value
<b>Preferred Name</b>	<b>Description@en</b>	<b>Dictionary / Classification System</b>
Prototype	The 3D model file represents a prototype state of the product.	[n/a] n/a
PilotRun	The 3D model file represents a pilot run state of the product.	[n/a] n/a
InSeries	The 3D model file represents the series state of the product.	[n/a] n/a
InterIn	The 3D model file represents an input state of an intermediate process (e.g., manufacturing).	[n/a] n/a
InterOut	The 3D model file represents an output state of an intermediate process (e.g., manufacturing).	[n/a] n/a



**Figure 113: ValueList – ModelPurpose**

**Table 104: ValueList – ModelPurpose**

<b>idShort:</b>	ModelPurpose (PosModelPurpose / NegModelPurpose)	
<b>Class:</b>	Property [Prop] [String]	
<b>semanticId:</b>	[IRI] <a href="https://admin-shell.io/idta/Models3D/Model3D/Capability/PosModelPurpose/1/0">https://admin-shell.io/idta/Models3D/Model3D/Capability/PosModelPurpose/1/0</a> [IRI] <a href="https://admin-shell.io/idta/Models3D/Model3D/Capability/NegModelPurpose/1/0">https://admin-shell.io/idta/Models3D/Model3D/Capability/NegModelPurpose/1/0</a>	
<b>Parent:</b>	[IRI] <a href="https://admin-shell.io/idta/Models3D/Model3D/Capability/1/0">https://admin-shell.io/idta/Models3D/Model3D/Capability/1/0</a> Capability	
<b>Explanation:</b>	Information about the intended purpose and usage (positive and negative) of the model.	
-	-	<b>semanticId = [idType]value</b>
<b>Preferred Name</b>	<b>Description@en</b>	<b>Dictionary / Classification System</b>
Logistics	The model file is/is not suitable for a logistics purpose.	[n/a] n/a
SimuMesh	The model file is/is not suitable to be meshed and used in a numerical simulation.	[n/a] n/a
VirtualCommissioning	The model file is/is not suitable to do virtual commissioning.	[n/a] n/a
3DPrintingSlicer	The model file is/is not suitable to be sliced and used for a 3D printing.	[n/a] n/a
Rendering	The model file is/is not suitable to be used for a rendering.	[n/a] n/a



**Figure 114: ValueList – ReducedElements**

**Table 105: ValueList – ReducedElements**

<b>idShort:</b>	ReducedElements	
<b>Class:</b>	Property [Prop] [String]	
<b>semanticId:</b>	[IRI] <a href="https://admin-shell.io/idta/Models3D/Model3D/Capability/ReducedElements/1/0">https://admin-shell.io/idta/Models3D/Model3D/Capability/ReducedElements/1/0</a>	
<b>Parent:</b>	[IRI] <a href="https://admin-shell.io/idta/Models3D/Model3D/Capability/1/0">https://admin-shell.io/idta/Models3D/Model3D/Capability/1/0</a> Capability	
<b>Explanation:</b>	Information about what elements were reduced, in comparison to the model this model was derived from.	
-	-	<b>semanticId = [idType]value</b>
<b>Preferred Name</b>	<b>Description@en</b>	<b>Dictionary / Classification System</b>
ScrewJoints	In comparison to the 3D model this model was derived from (see [Ref] DerivedFrom), screw joints were reduced.	[n/a] n/a
InnerParts	In comparison to the 3D model this model was derived from (see [Ref] DerivedFrom), inner parts were reduced.	[n/a] n/a
Graphics	In comparison to the 3D model this model was derived from (see [Ref] DerivedFrom), graphics were reduced.	[n/a] n/a



**Figure 115: ValueList – StatusValue**

**Table 106: ValueList – StatusValue**

<b>idShort:</b>	StatusValue	
<b>Class:</b>	Property [Prop] [String]	
<b>semanticId:</b>	[IRI] <a href="https://admin-shell.io/idta/Models3D/Model3D/File/FileVersion/StatusValue/1/0">https://admin-shell.io/idta/Models3D/Model3D/File/FileVersion/StatusValue/1/0</a>	
<b>Parent:</b>	[IRI] <a href="https://admin-shell.io/idta/Models3D/Model3D/File/FileVersion/1/0">https://admin-shell.io/idta/Models3D/Model3D/File/FileVersion/1/0</a> FileVersion	
<b>Explanation:</b>	Each file version represents a point in time in the file lifecycle. This status value refers to the milestones in the file lifecycle.	
-	-	<b>semanticId = [idType]value</b>
<b>Preferred Name</b>	<b>Description@en</b>	<b>Dictionary / Classification System</b>
InReview	The file is currently in the review process.	[IRDI] 0173-1#07-ABZ640#001 IDTA 02004-1-2
Released	The file is released.	[IRDI] 0173-1#07-ABZ641#001 IDTA 02004-1-2



Figure 116: ValueList – Representation

Table 107: ValueList – Representation

<b>idShort:</b>	Representation	
<b>Class:</b>	Property [Prop] [String]	
<b>semanticId:</b>	[IRI] <a href="https://admin-shell.io/idta/Models3D/Model3D/Geometry/Representation/1/0">https://admin-shell.io/idta/Models3D/Model3D/Geometry/Representation/1/0</a>	
<b>Parent:</b>	[IRI] <a href="https://admin-shell.io/idta/Models3D/Model3D/Geometry/1/0">https://admin-shell.io/idta/Models3D/Model3D/Geometry/1/0</a> Geometry	
<b>Explanation:</b>	Geometric representation of the model.	
-	-	<b>semanticId = [idType]value</b>
<b>Preferred Name</b>	<b>Description@en</b>	<b>Dictionary / Classification System</b>
SolidBody	The geometric representation is a solid body.	[n/a] n/a
WireFrame	The geometric representation is a wire frame.	[n/a] n/a
Surface	The geometric representation is a surface.	[n/a] n/a
Mesh	The geometric representation is a mesh.	[n/a] n/a
PointCloud	The geometric representation is a point cloud.	[n/a] n/a



Figure 117: ValueList – BoundingBoxKind

Table 108: ValueList – BoundingBoxKind

<b>idShort:</b>	BoundingBoxKind	
<b>Class:</b>	Property [Prop] [String]	
<b>semanticId:</b>	[IRI] <a href="https://admin-shell.io/idta/Models3D/Model3D/Geometry/CartBoundingBox/BoundingBoxKind/1/0">https://admin-shell.io/idta/Models3D/Model3D/Geometry/CartBoundingBox/BoundingBoxKind/1/0</a>	
<b>Parent:</b>	[IRI] <a href="https://admin-shell.io/idta/Models3D/Model3D/Geometry/CartBoundingBox/1/0">https://admin-shell.io/idta/Models3D/Model3D/Geometry/CartBoundingBox/1/0</a> CartBoundingBox	
<b>Explanation:</b>	Information about the kind of bounding box.	
-	-	semanticId = [idType]value
<b>Preferred Name</b>	<b>Description@en</b>	<b>Dictionary / Classification System</b>
MinEnvelope	The bounding box defines a cartesian minimum envelope around the 3D model.	[n/a] n/a
MaxEnvelope	The bounding box defines a cartesian maximum envelope around the 3D model.	[n/a] n/a

## 2.4 Common SubmodelElements [SME] within SMT Provision of 3D Models

This chapter contains the detailed description of SMEs that are reused – on a conceptual level, not on a modeling level – within the [SM] “Models3D”. Figure 118 shows the overview of the Common SME for the [SM] “Model3D”.

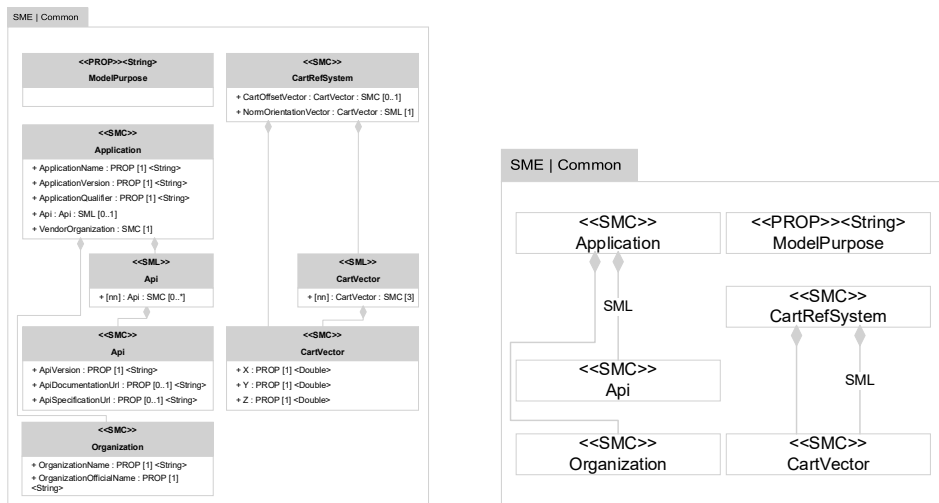

Figure 118: Common SubmodelElements [SME] within [SMT] Provision of 3D Models – Overview



Figure 119: CommonSubmodelElement [SMC] Application

Table 109: CommonSubmodelElement [SMC] Application

<b>idShort:</b>	Application		
<b>Class:</b>	SubmodelElementCollection [SMC]		
<b>semanticId:</b>	[IRI] <a href="https://admin-shell.io/idta/CommonClasses/Application/1/0">https://admin-shell.io/idta/CommonClasses/Application/1/0</a>		
<b>Parent:</b>	[IRI] <a href="https://admin-shell.io/idta/CommonClasses/1/0">https://admin-shell.io/idta/CommonClasses/1/0</a> CommonClasses		
<b>Explanation:</b>	Information about the application.		
<b>[SME type]</b>	<b>semanticId = [idType]value</b>	<b>[valueType]</b>	<b>card.</b>
<b>idShort</b>	<b>Description@en</b>	<b>example</b>	
[Prop] ApplicationName	[IRI] <a href="https://admin-shell.io/idta/CommonClasses/Application/ApplicationName/1/0">https://admin-shell.io/idta/CommonClasses/Application/ApplicationName/1/0</a> Name of the application.	[String] STEP	1
[Prop] ApplicationVersion	[IRI] <a href="https://admin-shell.io/idta/CommonClasses/Application/ApplicationVersion/1/0">https://admin-shell.io/idta/CommonClasses/Application/ApplicationVersion/1/0</a> Version of the application.	[String] SP242	1
[Prop] ApplicationQualifier	[IRI] <a href="https://admin-shell.io/idta/CommonClasses/Application/ApplicationQualifier/1/0">https://admin-shell.io/idta/CommonClasses/Application/ApplicationQualifier/1/0</a> Unique qualifier of the application.	[String] STEP-2.03	1
[SML] Api	[IRI] <a href="https://admin-shell.io/idta/CommonClasses/Application/Api/1/0">https://admin-shell.io/idta/CommonClasses/Application/Api/1/0</a> Information about how the application programming interfaces (APIs) of the application is defined.	[[SMC] Api]	0..*
[SMC] VendorOrganization	[IRI] <a href="https://admin-shell.io/idta/CommonClasses/Application/VendorOrganization/1/0">https://admin-shell.io/idta/CommonClasses/Application/VendorOrganization/1/0</a> Information about the tool vendor organization.	[[SMC] Organization]	1

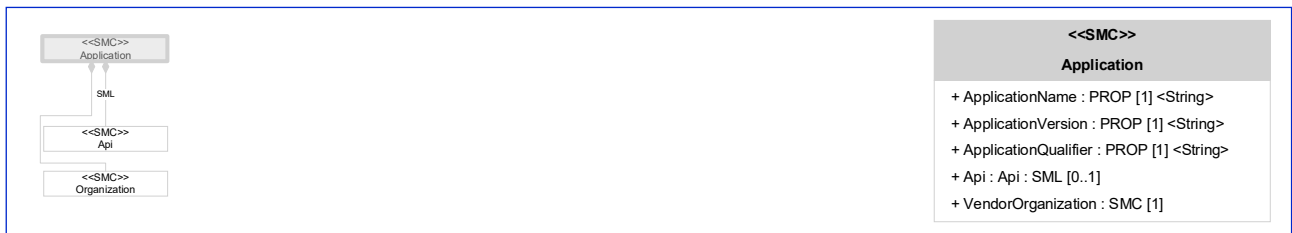

**Figure 120: CommonSubmodelElement [Prop] ApplicationName**

**Table 110: CommonSubmodelElement [Prop] ApplicationName**

<b>idShort:</b>	ApplicationName
<b>Class:</b>	Property [Prop] [String]
<b>semanticId:</b>	[IRI] <a href="https://admin-shell.io/idta/CommonClasses/ApplicationName/1/0">https://admin-shell.io/idta/CommonClasses/ApplicationName/1/0</a>
<b>Parent:</b>	[IRI] <a href="https://admin-shell.io/idta/CommonClasses/1/0">https://admin-shell.io/idta/CommonClasses/1/0</a> CommonClasses
<b>Explanation:</b>	Name of the application.

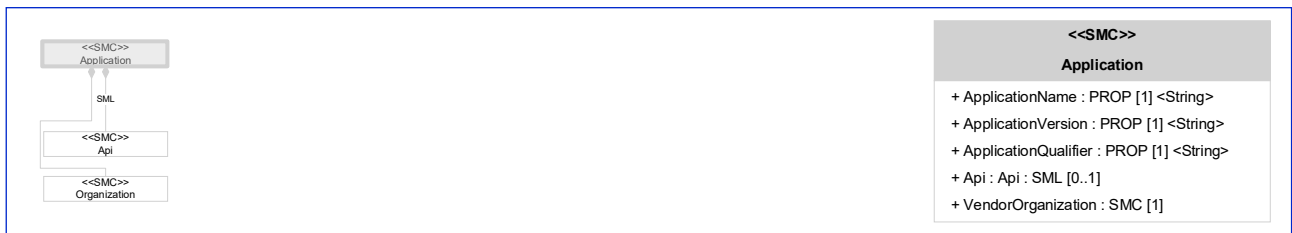

**Figure 121: CommonSubmodelElement [Prop] ApplicationVersion**

**Table 111: CommonSubmodelElement [Prop] ApplicationVersion**

<b>idShort:</b>	ApplicationVersion
<b>Class:</b>	Property [Prop] [String]
<b>semanticId:</b>	[IRI] <a href="https://admin-shell.io/idta/CommonClasses/ApplicationVersion/1/0">https://admin-shell.io/idta/CommonClasses/ApplicationVersion/1/0</a>
<b>Parent:</b>	[IRI] <a href="https://admin-shell.io/idta/CommonClasses/1/0">https://admin-shell.io/idta/CommonClasses/1/0</a> CommonClasses
<b>Explanation:</b>	Version of the application.



**Figure 122: CommonSubmodelElement [Prop] ApplicationQualifier**

**Table 112: CommonSubmodelElement [Prop] ApplicationQualifier**

<b>idShort:</b>	ApplicationQualifier
<b>Class:</b>	Property [Prop] [String]
<b>semanticId:</b>	[IRI] <a href="https://admin-shell.io/idta/CommonClasses/ApplicationQualifier/1/0">https://admin-shell.io/idta/CommonClasses/ApplicationQualifier/1/0</a>
<b>Parent:</b>	[IRI] <a href="https://admin-shell.io/idta/CommonClasses/1/0">https://admin-shell.io/idta/CommonClasses/1/0</a> CommonClasses
<b>Explanation:</b>	Unique qualifier of the application.



**Figure 123: CommonSubmodelElement [SMC] Api**

**Table 113: CommonSubmodelElement [SMC] Api**

<b>idShort:</b>	Api		
<b>Class:</b>	SubmodelElementCollection [SMC]		
<b>semanticId:</b>	[IRI] <a href="https://admin-shell.io/idta/CommonClasses/Api/1/0">https://admin-shell.io/idta/CommonClasses/Api/1/0</a>		
<b>Parent:</b>	[IRI] <a href="https://admin-shell.io/idta/CommonClasses/1/0">https://admin-shell.io/idta/CommonClasses/1/0</a> CommonClasses		
<b>Explanation:</b>	Information about how the application programming interfaces (APIs) of the application is defined.		
<b>[SME type]</b>	<b>semanticId = [idType]value</b>	<b>[valueType]</b>	<b>card.</b>
<b>idShort</b>	<b>Description@en</b>	<b>example</b>	
[Prop] ApiVersion	[IRI] <a href="https://admin-shell.io/idta/CommonClasses/Api/ApiVersion/1/0">https://admin-shell.io/idta/CommonClasses/Api/ApiVersion/1/0</a> Description of the version of the API	[String] OpenAPI Specification – Version 3.0.1	1
[Prop] ApiDocumentationUrl	[IRI] <a href="https://admin-shell.io/idta/CommonClasses/Api/ApiDocumentationUrl/1/0">https://admin-shell.io/idta/CommonClasses/Api/ApiDocumentationUrl/1/0</a> Link to the documentation of the API.	[String] <a href="https://learn.openapis.org/">https://learn.openapis.org/</a>	0..1
[Prop] ApiSpecificationUrl	[IRI] <a href="https://admin-shell.io/idta/CommonClasses/Api/ApiSpecificationUrl/1/0">https://admin-shell.io/idta/CommonClasses/Api/ApiSpecificationUrl/1/0</a> Link to the specification of the API.	[String] <a href="https://github.com/OAI/OpenAPI-Specification/blob/main/versions/3.0.1.md">https://github.com/OAI/OpenAPI-Specification/blob/main/versions/3.0.1.md</a>	0..1



Figure 124: CommonSubmodelElement [Prop] ApiVersion

Table 114: CommonSubmodelElement [Prop] ApiVersion

<b>idShort:</b>	ApiVersion
<b>Class:</b>	Property [Prop] [String]
<b>semanticId:</b>	[IRI] <a href="https://admin-shell.io/idta/CommonClasses/Api/ApiVersion/1/0">https://admin-shell.io/idta/CommonClasses/Api/ApiVersion/1/0</a>
<b>Parent:</b>	[IRI] <a href="https://admin-shell.io/idta/CommonClasses/Api/1/0">https://admin-shell.io/idta/CommonClasses/Api/1/0</a> Api
<b>Explanation:</b>	Description of the version of the API



Figure 125: CommonSubmodelElement [Prop] ApiDocumentationUri

Table 115: CommonSubmodelElement [Prop] ApiDocumentationUri

<b>idShort:</b>	ApiDocumentationUri
<b>Class:</b>	Property [Prop] [String]
<b>semanticId:</b>	[IRI] <a href="https://admin-shell.io/idta/CommonClasses/Api/ApiVersion/ApiDocumentationUri/1/0">https://admin-shell.io/idta/CommonClasses/Api/ApiVersion/ApiDocumentationUri/1/0</a>
<b>Parent:</b>	[IRI] <a href="https://admin-shell.io/idta/CommonClasses/Api/1/0">https://admin-shell.io/idta/CommonClasses/Api/1/0</a> Api
<b>Explanation:</b>	Link to the specification of the API.



**Figure 126: CommonSubmodelElement [Prop] ApiSpecificationUrl**

**Table 116: CommonSubmodelElement [Prop] ApiSpecificationUrl**

<b>idShort:</b>	ApiSpecificationUrl
<b>Class:</b>	Property [Prop] [String]
<b>semanticId:</b>	[IRI] <a href="https://admin-shell.io/idta/CommonClasses/Api/ApiSpecificationUrl/1/0">https://admin-shell.io/idta/CommonClasses/Api/ApiSpecificationUrl/1/0</a>
<b>Parent:</b>	[IRI] <a href="https://admin-shell.io/idta/CommonClasses/Api/1/0">https://admin-shell.io/idta/CommonClasses/Api/1/0</a> Api
<b>Explanation:</b>	Link to the documentation of the API.



**Figure 127: CommonSubmodelElement [SMC] Organization**

**Table 117: CommonSubmodelElement [SMC] Organization**

<b>idShort:</b>	Organization		
<b>Class:</b>	SubmodelElementCollection [SMC]		
<b>semanticId:</b>	[IRI] <a href="https://admin-shell.io/idta/CommonClasses/Organization/1/0">https://admin-shell.io/idta/CommonClasses/Organization/1/0</a>		
<b>Parent:</b>	[IRI] <a href="https://admin-shell.io/idta/CommonClasses/1/0">https://admin-shell.io/idta/CommonClasses/1/0</a> CommonClasses		
<b>Explanation:</b>	Information about the organization in general.		
<b>[SME type]</b>	<b>semanticId = [idType]value</b>	<b>[valueType]</b>	<b>card.</b>
<b>idShort</b>	<b>Description@en</b>	<b>example</b>	
[Prop] OrganizationName	[IRI] <a href="https://admin-shell.io/idta/CommonClasses/Organization/OrganizationName/1/0">https://admin-shell.io/idta/CommonClasses/Organization/OrganizationName/1/0</a> Short name of the organization.	[String] IDTA	1
[Prop] OrganizationOfficialName	[IRI] <a href="https://admin-shell.io/idta/CommonClasses/Organization/OrganizationOfficialName/1/0">https://admin-shell.io/idta/CommonClasses/Organization/OrganizationOfficialName/1/0</a> Official name of the organization.	[String] Industrial Digital Twin Association e. V.	1



**Figure 128: CommonSubmodelElement [Prop] OrganizationName**

**Table 118: CommonSubmodelElement [Prop] OrganizationOfficialName**

<b>idShort:</b>	OrganizationName
<b>Class:</b>	Property [Prop] [String]
<b>semanticId:</b>	[IRI] <a href="https://admin-shell.io/idta/CommonClasses/OrganizationName/1/0">https://admin-shell.io/idta/CommonClasses/OrganizationName/1/0</a>
<b>Parent:</b>	[IRI] <a href="https://admin-shell.io/idta/CommonClasses/1/0">https://admin-shell.io/idta/CommonClasses/1/0</a> CommonClasses
<b>Explanation:</b>	Short name of the organization.

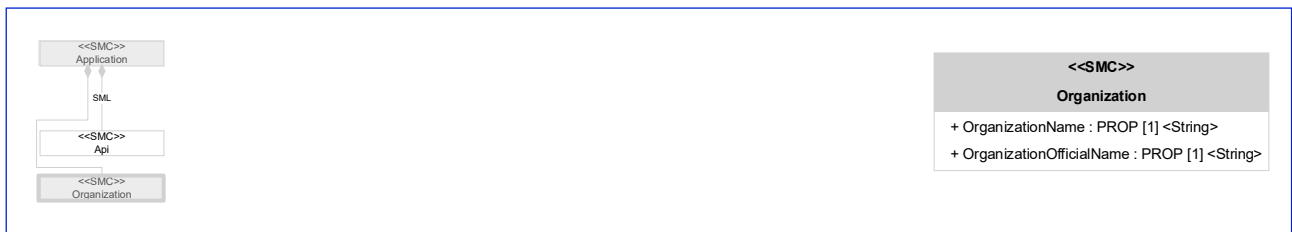

**Figure 129: CommonSubmodelElement [Prop] OrganizationOfficialName**

**Table 119: CommonSubmodelElement [Prop] OrganizationOfficialName**

<b>idShort:</b>	OrganizationOfficialName
<b>Class:</b>	Property [Prop] [String]
<b>semanticId:</b>	[IRI] <a href="https://admin-shell.io/idta/CommonClasses/OrganizationOfficialName/1/0">https://admin-shell.io/idta/CommonClasses/OrganizationOfficialName/1/0</a>
<b>Parent:</b>	[IRI] <a href="https://admin-shell.io/idta/CommonClasses/1/0">https://admin-shell.io/idta/CommonClasses/1/0</a> CommonClasses
<b>Explanation:</b>	Official name of the organization.

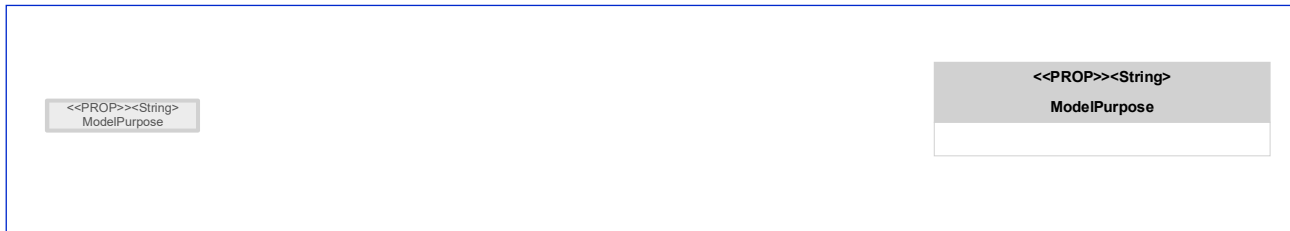

**Figure 130: CommonSubmodelElement [Prop] ModelPurpose**

**Table 120: CommonSubmodelElement [Prop] ModelPurpose**

<b>idShort:</b>	ModelPurpose
<b>Class:</b>	Property [Prop] [String]
<b>semanticId:</b>	[IRI] <a href="https://admin-shell.io/idta/CommonClasses/ModelPurpose/1/0">https://admin-shell.io/idta/CommonClasses/ModelPurpose/1/0</a>
<b>Parent:</b>	[IRI] <a href="https://admin-shell.io/idta/CommonClasses/1/0">https://admin-shell.io/idta/CommonClasses/1/0</a> CommonClasses
<b>Explanation:</b>	Information about the intended purpose and usage (positive and negative) of the model.



**Figure 131: CommonSubmodelElement [SMC] CartRefSystem**

**Table 121: CommonSubmodelElement [SMC] CartRefSystem**

<b>idShort:</b>	CartRefSystem		
<b>Class:</b>	SubmodelElementCollection [SMC]		
<b>semanticId:</b>	[IRI] <a href="https://admin-shell.io/idta/CommonClasses/CartRefSystem/1/0">https://admin-shell.io/idta/CommonClasses/CartRefSystem/1/0</a>		
<b>Parent:</b>	[IRI] <a href="https://admin-shell.io/idta/CommonClasses/1/0">https://admin-shell.io/idta/CommonClasses/1/0</a> CommonClasses		
<b>Explanation:</b>	Cartesian reference system.		
<b>[SME type]</b>	<b>semanticId = [idType]value</b>	<b>[valueType]</b>	<b>card.</b>
<b>idShort</b>	<b>Description@en</b>	<b>example</b>	
[SMC] CartOffsetVector	[IRI] <a href="https://admin-shell.io/idta/CommonClasses/CartRefSystem/CartOffsetVector/1/0">https://admin-shell.io/idta/CommonClasses/CartRefSystem/CartOffsetVector/1/0</a> Cartesian offset vector of the cartesian reference system.	[[SMC] CartVector]	0..1
[SMC] NormOrientationVector	[IRI] <a href="https://admin-shell.io/idta/CommonClasses/CartRefSystem/NormOrientationVector/1/0">https://admin-shell.io/idta/CommonClasses/CartRefSystem/NormOrientationVector/1/0</a> Cartesian norm vector of the cartesian reference system.	[[SMC] CartVector]	1

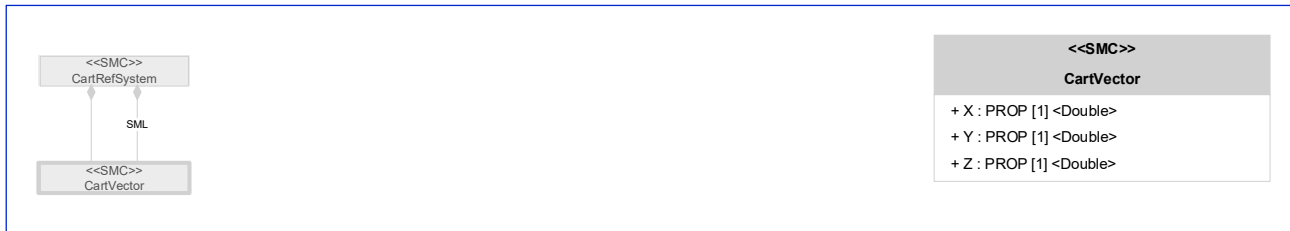

Figure 132: CommonSubmodelElement [SMC] CartVector

Table 122: CommonSubmodelElement [SMC] CartVector

<b>idShort:</b>	CartVector		
<b>Class:</b>	SubmodelElementCollection [SMC]		
<b>semanticId:</b>	[IRI] <a href="https://admin-shell.io/idta/CommonClasses/CartVector/1/0">https://admin-shell.io/idta/CommonClasses/CartVector/1/0</a>		
<b>Parent:</b>	[IRI] <a href="https://admin-shell.io/idta/CommonClasses/1/0">https://admin-shell.io/idta/CommonClasses/1/0</a> CommonClasses		
<b>Explanation:</b>	General cartesian vector.		
<b>[SME type]</b>	<b>semanticId = [idType]value</b>	<b>[valueType]</b>	<b>card.</b>
<b>idShort</b>	<b>Description@en</b>	<b>example</b>	
[Prop] X	[IRI] <a href="https://admin-shell.io/idta/CommonClasses/CartOffsetVector/X/1/0">https://admin-shell.io/idta/CommonClasses/CartOffsetVector/X/1/0</a> X component of the cart vector. Always state the unit.	[Double] 42	1
[Prop] Y	[IRI] <a href="https://admin-shell.io/idta/CommonClasses/CartOffsetVector/Y/1/0">https://admin-shell.io/idta/CommonClasses/CartOffsetVector/Y/1/0</a> Y component of the cart vector. Always state the unit.	[Double] 42	1
[Prop] Z	[IRI] <a href="https://admin-shell.io/idta/CommonClasses/CartOffsetVector/Z/1/0">https://admin-shell.io/idta/CommonClasses/CartOffsetVector/Z/1/0</a> Z component of the cart vector. Always state the unit.	[Double] 42	1



Figure 133: CommonSubmodelElement [Prop] X

Table 123: CommonSubmodelElement [Prop] X

<b>idShort:</b>	X
<b>Class:</b>	Property [Prop] [Double]
<b>semanticId:</b>	[IRI] <a href="https://admin-shell.io/idta/CommonClasses/X/1/0">https://admin-shell.io/idta/CommonClasses/X/1/0</a>
<b>Parent:</b>	[IRI] <a href="https://admin-shell.io/idta/CommonClasses/1/0">https://admin-shell.io/idta/CommonClasses/1/0</a> CommonClasses
<b>Explanation:</b>	X component of the cart vector. Always state the unit.



Figure 134: CommonSubmodelElement [Prop] Y

Table 124: CommonSubmodelElement [Prop] Y

<b>idShort:</b>	Y
<b>Class:</b>	Property [Prop] [Double]
<b>semanticId:</b>	[IRI] <a href="https://admin-shell.io/idta/CommonClasses/Y/1/0">https://admin-shell.io/idta/CommonClasses/Y/1/0</a>
<b>Parent:</b>	[IRI] <a href="https://admin-shell.io/idta/CommonClasses/1/0">https://admin-shell.io/idta/CommonClasses/1/0</a> CommonClasses
<b>Explanation:</b>	Y component of the cart vector. Always state the unit.

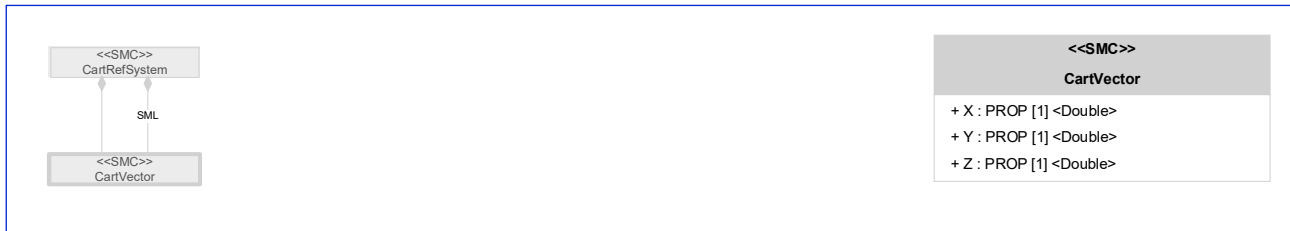

Figure 135: CommonSubmodelElement [Prop] Z

Table 125: CommonSubmodelElement [Prop] Z

<b>idShort:</b>	Z
<b>Class:</b>	Property [Prop] [Double]
<b>semanticId:</b>	[IRI] <a href="https://admin-shell.io/idta/CommonClasses/Z/1/0">https://admin-shell.io/idta/CommonClasses/Z/1/0</a>
<b>Parent:</b>	[IRI] <a href="https://admin-shell.io/idta/CommonClasses/1/0">https://admin-shell.io/idta/CommonClasses/1/0</a> CommonClasses
<b>Explanation:</b>	Z component of the cart vector. Always state the unit.

# Annex A. Explanations on used table formats

## 1. General

The used tables in this document try to outline information as concise as possible. They do not convey all information on Submodels and SubmodelElements. For this purpose, the definitive definitions are given by a separate file in form of an AASX file of the Submodel template and its elements.

## 2. Tables on Submodels and SubmodelElements

For clarity and brevity, a set of rules is used for the tables for describing Submodels and SubmodelElements.

- The tables follow in principle the same conventions as in [5].
- The table heads abbreviate 'cardinality' with 'card'.
- The tables often place two informations in different rows of the same table cell. In this case, the first information is marked out by sharp brackets [] from the second information. A special case are the semanticIds, which are marked out by the format: (type)(local)[idType]value.
- The types of SubmodelElements are abbreviated:

SME type	SubmodelElement type
Prop	Property
MLP	MultiLanguageProperty
Range	Range
Range	Range
Ent	Entity
Evt	Event
File	File
Blob	Blob
Opr	Operation
Ref	ReferenceElement
Rel	RelationshipElement
SM	Submodel
SMC	SubmodelElementCollection
SML	SubmodelElementList

- If an idShort ends with '{00}', this indicates a suffix of the respective length (here: 2) of decimal digits, in order to make the idShort unique. A different idShort might be chosen, as long as it is unique in the parent's context.
- The Keys of semanticId in the main section feature only idType and value, such as: [IRI]https://admin-shell.io/vdi/2770/1/0/DocumentId/Id. The attributes "type" and "local" (typically "ConceptDescription" and "(local)" or "GlobalReference" and "(no-local)") need to be set accordingly; see [6].
- If a table does not contain a column with "parent" heading, all represented attributes share the same parent. This parent is denoted in the head of the table.
- Multi-language strings are represented by the text value, followed by '@'-character and the ISO 639 language code: example@EN.
- The [valueType] is only given for Properties.

## Annex B. Application guidelines and scenarios

To make the implementation of the SMT IDTA 02026-1-0 “Provision of 3D Models” easier, and to show what was the intention of the working group while designing the [SM] “Models3D”, this chapter will give guidelines and scenarios how to apply the [SM] “Models3D”.

### 1. Guidelines

This chapter includes guidelines of what is recommended and what should be avoided by applying the [SM] “Models3D”.

#### 1.1. Avoid providing more 3D model files than necessary

To avoid unnecessary data exchange, it is not recommended to provide all available file formats and versions at once within:

- [SMC] FileVersion
  - Table 9
  - [IRI] <https://admin-shell.io/idta/Models3D/Model3D/File/FileVersion/1/0>

It is recommended to exchange only the file versions that are needed. And to link to an external file source if necessary. This could e.g., be done by the selection of:

- [Prop] FileVersionId
  - Table 12
  - [IRI] <https://admin-shell.io/idta/Models3D/Model3D/File/FileVersion/FileVersionId/1/0>
- [Prop] StatusValue
  - Table 13
  - [IRI] <https://admin-shell.io/idta/Models3D/Model3D/File/FileVersion/StatusValue/1/0>
- [Prop] SetDate
  - Table 14
  - [IRI] <https://admin-shell.io/idta/Models3D/Model3D/File/FileVersion/SetDate/1/0>
- [Prop] ApplicationName
  - Table 34
  - [IRI] <https://admin-shell.io/idta/Models3D/Model3D/File/FileVersion/SourceApplication/ApplicationName/1/0>
- [Prop] ApplicationVersion
  - Table 35
  - [IRI] <https://admin-shell.io/idta/Models3D/Model3D/File/FileVersion/SourceApplication/ApplicationVersion/1/0>
- [Prop] ApplicationQualifier
  - Table 36
  - [IRI] <https://admin-shell.io/idta/Models3D/Model3D/File/FileVersion/SourceApplication/ApplicationQualifier/1/0>

#### 1.2. Avoid redefining geometric information

Don't overload the geometry [SMC] Geometry (Table 73) by redefining too much elements already defined in the 3D model file. Define:

- [SMC] CartBoundingBox
  - Table 76
  - [IRI] <https://admin-shell.io/idta/Models3D/Model3D/Geometry/CartBoundingBox/1/0>

- [SMC] CartRefSystem
  - Table 78
  - [IRI] <https://admin-shell.io/idta/Models3D/Model3D/Geometry/CartRefSystem/1/0>

only if it is reasonable for the intended use cases, e.g., to check quick if the Asset suits a transport box without having or opening the 3D model file. Or providing geometric information about some interfaces.

## Annex C. Backlog

This Annex C includes Table 126 that shows the backlog containing issues elaborated and consolidated during the working group meetings across all releases and meetings of the SMT IDTA 02026 “Provision of 3D Models”. This backlog is the basis for the [SM] development. It should provide an overview of what topics:

- were discussed,
- are addressed in which release and to what depth,
- are not part of this [SM] and why.

**Table 126: Backlog**

Issue	Description	Addressed
3D model file provision	Should include 3D model file, description of the model format and version information.  Orientated on SMT IDTA 02004-1-2 “Handover Documentation” with [SM] “HandoverDocumentation” and SMT IDTA 02005-1-0 “Provision of Simulation Models” with [SM] “SimulationModels”.	V1
Purpose / Capability / Level of Detail	Description of what is the 3D model I have in front of me capable of. Can it be used for e.g., 3D printing, or kinetics? Was the Level-Of-Detail reduced e.g., due to performance reasons?  Model Purpose orientated on SMT IDTA 02005-1-0 “Provision of Simulation Models”	V1
Configurators / Parameterization	Should not include configuration logic.  Should include information to retrieve a specific configuration from a server. Moved to [SMC] ExternalFile  Suits also the scope of SMT IDTA 02003-1-2 “Generic Frame for Technical Data for Industrial Equipment in Manufacturing” with [SM] “TechnicalData”	V1
Fast Integration	Plug and Play in CAX/PDM Environment.  General requirement.	-
Placement aid / installation spaces / reference coordinate systems (with center of gravity)	Should not redefine too many features of the 3D model files itself.  Should include basic set of SMCs to describe a bounding box and, if necessary, reference points.  VDMA working group has proposed some parameters in elaboration with ECLASS.	V1 (basic coordinate System)
Versioning / Change Management / Release	Are the meta information in the [SM] and the 3D model file up to date?  General topic for all SM.	-
Transfer parameters / references / continuity / automatability between [SM] / AAS	E.g., use 3D Model file in simulation environment, link piping and instrumentation diagram (PID) with bill of materials (BOM)  General topic. First use cases elaborate in SMT IDTA 02005-1-0 “Provision of Simulation Models”.  Split further and evaluate in future [SM] development.	-
Product and manufacturing information (PMI)	Definition about the scope within this [SM] are required. PMIs are part of the 3D model file itself.	V1 (Info if PMI is available)

Issue	Description	Addressed
Virtual Commissioning	<p>What do I expect from 3D Model files and meta data during virtual commissioning? E.g., includes the 3D Model kinematics?</p> <p>Addressed strongly by SMT IDTA 02005-1-0 "Provision of Simulation Models".</p>	V1 (Info if suitable for purpose)
Kinematics	<p>What axis offers which degree of freedom? What is the no. of coordinate systems? Support during integration.</p>	V1 (Info if kinematics are available)
Measurement behavior	<p>Main scope in in SMT IDTA 02029-1-0 "Sensor 4.0"</p>	-
Data integrity and billing	<p>Intellectual property (IP) protection e.g. with non-fungible tokens (NFT). Authentication to support billing and monetization.</p> <p>General topic: belongs to AAS Meta Model (authenticity / encryption)</p>	-
Predesign / Screening	<p>How do I quickly find the suitable model? Search process usually starts with technical requirements and not with 3D model file.</p> <p>Main scope in SMT IDTA 02003-1-2 "Generic Frame for Technical Data for Industrial Equipment in Manufacturing"</p> <p>Addressed by IDTA Task Force "Discovery"</p> <p>Not part of IDTA SMT 020026 "Provision of 3D Models"</p>	-
Domain (+Contact)	<p>Direct contact to specialized department.</p> <p>Concept addressed by SMT IDTA 02005-1-0 "Provision of Simulation Models" and SMT IDTA 02002-1-0 "Submodel for Contact Information".</p> <p>Dedicated contact in IDTA SMT 020026 "Provision of 3D Models" not desirable.</p>	-
Equipment labeling tag (BMK)	<p>Betriebsmittelkennzeichen (BMK)</p> <p>Linkage of 3D Model, to piping and instrumentation diagram (PID) and bill of materials (BOM).</p>	-
Companion files	<p>Provides e.g., Wavefront file format (*.obj and companion *.mtl) for basic material inside applications.</p>	-
Interfaces	<p>Where are interfaces located geometrically?</p>	V1 (basic coordinate System)
ISO GPS	<p>ISO 14638 Geometrical product specifications (GPS) should be addressed.</p> <p>Part of the 3D model file or a 2D model derivation.</p>	-

# Annex D. Diagrams

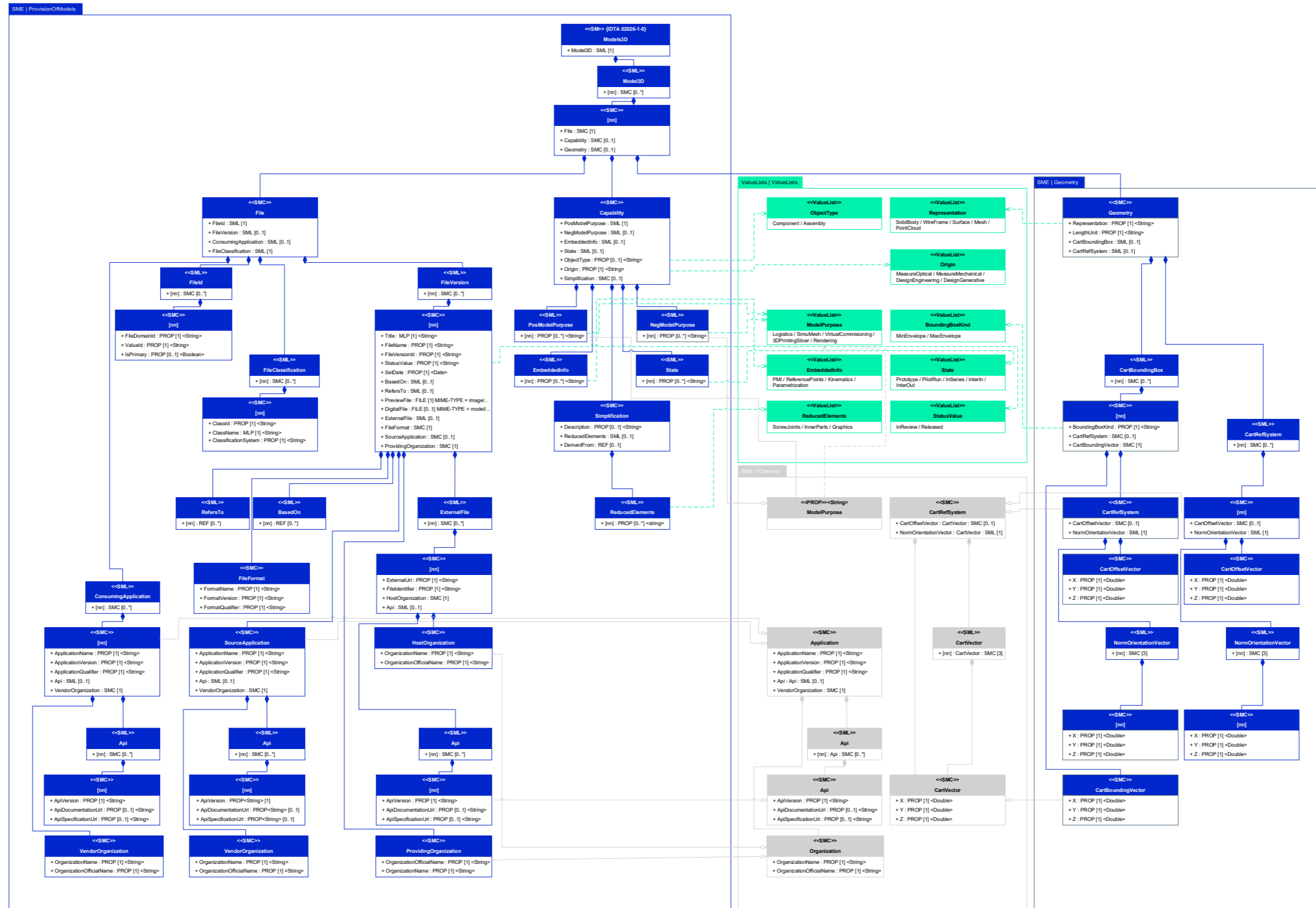

Figure 136: UML | SMT IDTA 02026-1-0 Provision of 3D Models – enlarged

## Bibliography

- [1] “Recommendations for implementing the strategic initiative INDUSTRIE 4.0”, acatech, April 2013. [Online]. Available <https://www.acatech.de/Publikation/recommendations-for-implementing-the-strategic-initiative-industrie-4-0-final-report-of-the-industrie-4-0-working-group/>
- [2] “Implementation Strategy Industrie 4.0: Report on the results of the Industrie 4.0 Platform”; BITKOM e.V. / VDMA e.V., /ZVEI e.V., April 2015. [Online]. Available: <https://www.bitkom.org/noindex/Publikationen/2016/Sonstiges/Implementation-Strategy-Industrie-40/2016-01-Implementation-Strategy-Industrie40.pdf>
- [3] “The Structure of the Administration Shell: TRILATERAL PERSPECTIVES from France, Italy and Germany”, March 2018, [Online]. Available: <https://www.plattform-i40.de/I40/Redaktion/EN/Downloads/Publikation/hm-2018-trilaterale-coop.html>
- [4] “Beispiele zur Verwaltungsschale der Industrie 4.0-Komponente – Basisteil (German)”; ZVEI e.V., Whitepaper, November 2016. [Online]. Available: <https://www.zvei.org/presse-medien/publikationen/beispiele-zur-verwaltungsschale-der-industrie-40-komponente-basisteil/>
- [5] “Verwaltungsschale in der Praxis. Wie definiere ich Teilmodelle, beispielhafte Teilmodelle und Interaktion zwischen Verwaltungsschalen (in German)”, Version 1.0, April 2019, Plattform Industrie 4.0 in Kooperation mit VDE GMA Fachausschuss 7.20, Federal Ministry for Economic Affairs and Energy (BMWi), Available: <https://www.plattform-i40.de/PI40/Redaktion/DE/Downloads/Publikation/2019-verwaltungsschale-in-der-praxis.html>
- [6] “Details of the Asset Administration Shell; Part 1 - The exchange of information between partners in the value chain of Industrie 4.0 (Version 3.0RC01)”, November 2020, [Online]. Available: <https://www.plattform-i40.de/PI40/Redaktion/EN/Downloads/Publikation/Details-of-the-Asset-Administration-Shell-Part1.html>

[www.industrialdigitaltwin.org](http://www.industrialdigitaltwin.org)